



Chunghwa Picture Tubes, Ltd.

Product Specification

To : DATA MODUL

Date : 081218

TFT LCD

CLAA070LC0ACW

ACCEPTED BY : (V1.2)

APPROVED BY	CHECKED BY	PREPARED BY
張聖暉	李家銘	陳儀華

Prepared by :

Product Planning Management Division
Small & Medium TFT Product Business Unit

CHUNGHWA PICTURE TUBES, LTD.

1127 Hopin Rd., Padeh, Taoyuan, Taiwan 334, R.O.C.
TEL: +886-3-3675151 FAX: +886-3-377-3858

Doc.No: SPEC_CLAA070LC0ACW_V1.2_DATA MODUL_081218

Issue Date: 2008/12/17

Contents

1. OVERVIEW	4
2. ABSOLUTE MAXIMUM RATINGS	5
3. ELECTRICAL CHARACTERISTICS	6
3.1 TFT LCD	6
3.2 TFT-LCD Current Consumption	7
3.3 Power 、Signal sequence.....	7
3.4 Backlight.....	7
4. INTERFACE CONNECTION	8
5. INPUT SIGNAL(DE ONLY MODE)	10
5.1 Timing Specification	10
5.2 Timing sequence(Timing chart).....	10
5.3 Color Data Assignment.....	12
7. BLOCK DIAGRAM	13
8. MECHANICAL DIMENSION	14
8.1 Front Side	14
8.2 Rear Side	14
9. OPTICAL CHARACTERISTICS	15
10. RELIABILITY TEST	17
10.1. Temperature and humidity.....	17
10.2. Shock and Vibration.....	17
10.3 Electrostatic Discharge.....	17
10.4 MTBF.....	17
10.5 Judgment standard	17

1. OVERVIEW

CLAA070LC0ACW is 7" color TFT-LCD(Thin Film Transistor Liquid Crystal Display)module .Composed of LCD panel,driver ICs,control circuit,and LED backlight.

The 7.0"screen produces a high resolution image that is composed of 800×480 pixel elements in a stripe arrangement.Display 262K colors by 6 Bit R.G.B signal input.

General specifications are summarized in the following table :

ITEM	SPECIFICATION
Display Area (mm)	152.4(W)×91.44(H)
Number of Pixels	800(H)×3(RGB)×480(V)
Pixel Pitch (mm)	0.1905(H)×0.1905(V)
Color Pixel Arrangement	RGB vertical stripe
Display Mode	Normally white
Number of colors	262,144
Viewing Direction	6 o'clock
Response Time (Tr+Tf)	20ms
Brightness(cd/m ²)	220nit(typ)
Viewing Angle(BL on,CR≥10)	140 degree(H) , 110degree(V)
Electrical Interface(data)	TTL
Power consumption	2.0W(Typ)
Outline Dimension(in mm)	165(W)×104(H)×5(D)
Weight(g)	115
BL unit	LED
Surface Treatment	Anti-Glare , Hardness:3H

2. ABSOLUTE MAXIMUM RATINGS

Item	Symbol	Min.	Max.	Unit	Note
Input Voltage	Vcc	-0.5	5.0	V	
Signal Input Voltage	DCLK,DE,R0,G0,B0~R5,G5,B5	-0.5	Vcc+0.5	V	
Static Electricity	VESDc	-200	200	V	【Note1】
	VESDm	-15K	15K	V	
ICC Rush Current	IRUSH	-	1	A	【Note2】

【Note1】

Test Condition: IEC 61000-4-2 ,

VESDc : Contact discharge to input connector

VESDm : Discontact discharge to module

【Note2】

Control signal:High(+3.3V)→Low(GND)

Supply Voltage of rising time should be from R3 and C2 tune to 550 us.

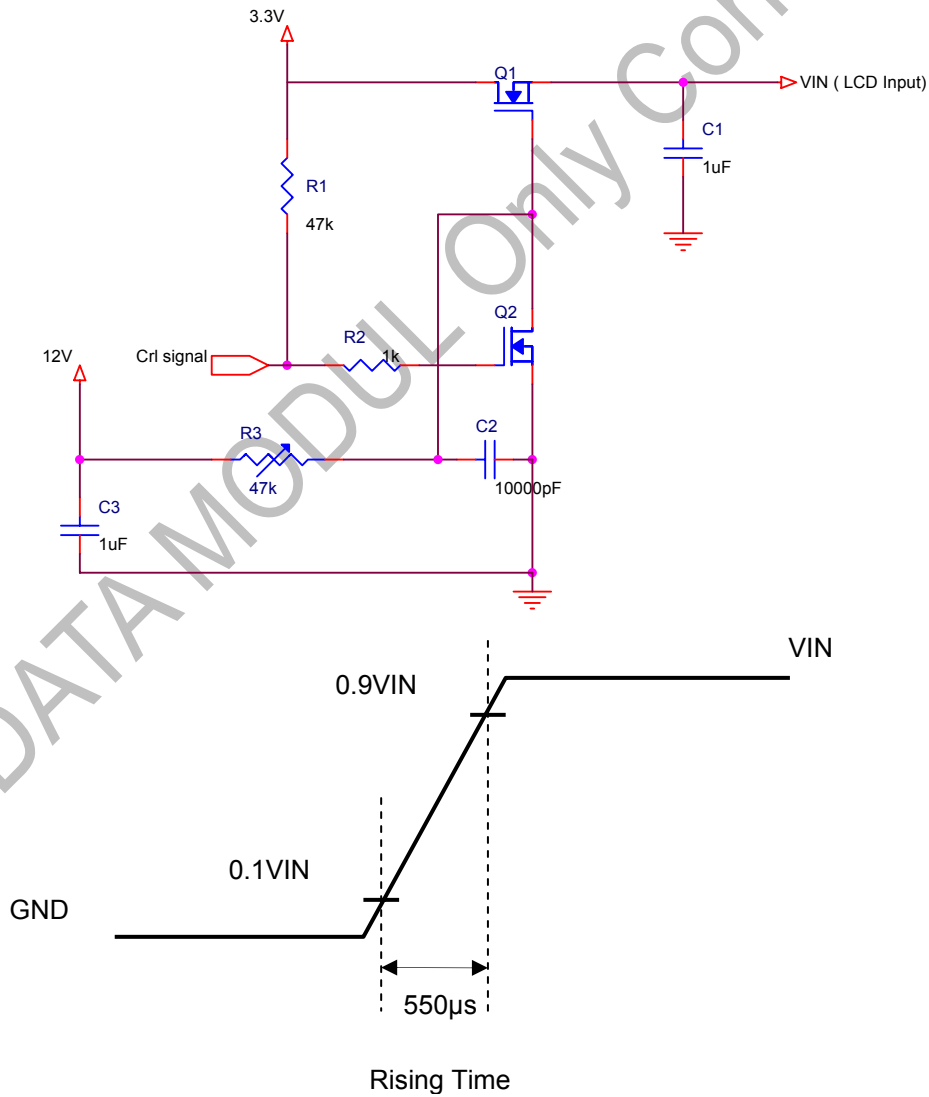

3. ELECTRICAL CHARACTERISTICS

3.1 TFT LCD

Ta=25

Item	Symbol	Min.	Typ	Max.	Unit	Note
Power Supply Voltage For LCD	VCC	3.0	3.3	3.6	V	【Note1】
Power Supply Voltage For LED	VLED	4.5	5	5.5	V	
Logic Input Voltage	VIH	VCC*0.7	--	VCC	V	
	VIL	GND	--	VCC*0.3	V	
ADJ Input Voltage	Threshold Voltage(high)	VADJ_H	3.0	--	3.3	V
	Threshold Voltage(low)	VADJ_L	GND	--	0.3	V

Remarks :

【Note1】

VCC –dip condition:

- 1) When 2.7 V $VCC < 3.0V$, $t_d \leq 10ms$.
- 2) When $VCC < 3.0V$, it works abnormal that must reset power.
VCC dip conditions should follow VCC turn on conditions

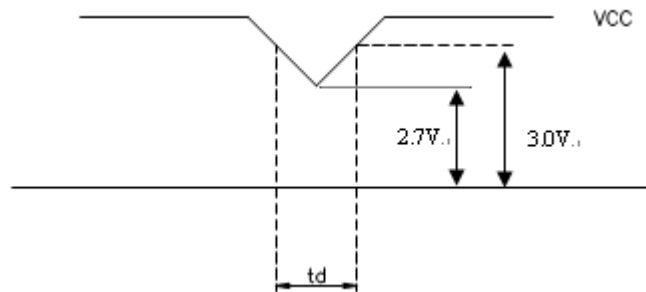

3.2 TFT-LCD Current Consumption

Item	Symbol	Min	Type	Max	Unit	Notes
LCD power current	ICC	--	150	200	mA	【Note1】
LED power current	ILED		300	350	mA	【Note2】

【Note1】

Typical: Under 64 gray pattern
 Maximum: Under black pattern



(a) 64 Gray Pattern

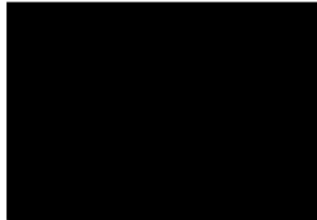

(b) Black Pattern

【Note2】

Typical: When VLED is 5V
 Maximum: When VLED is 4.5V

3.3 Power 、 Signal sequence

- t1 10ms 1 sec t5
- 0 < t2 50ms 200ms t6
- 0 < t3 50ms 200ms t7
- 0 < t4 10ms

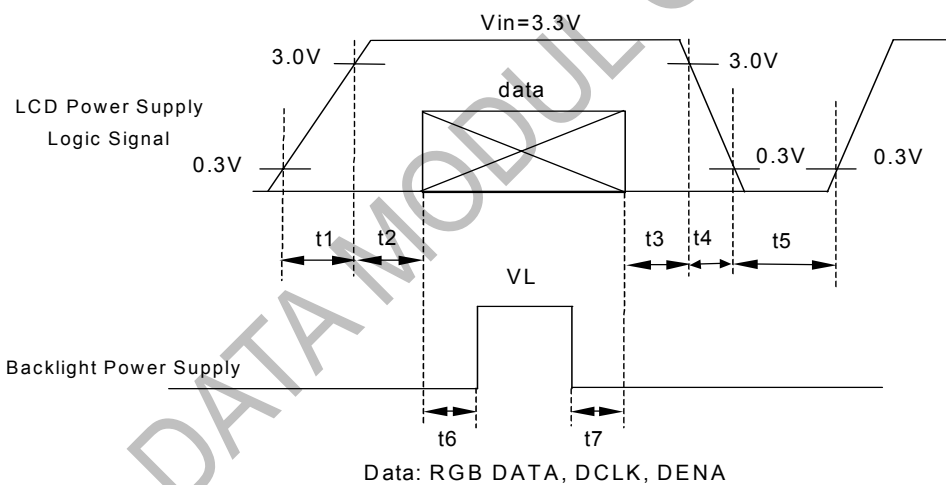

3.4 Backlight

Ta=25

ITEM	SYMBOL	MIN.	TYP.	MAX.	UNIT	NOTE
LED Lift Time	N/A	12,000			Hour	【Note1】

【Note1】 Definition of life time : Luminance < 50% initial value

4. INTERFACE CONNECTION

4.1 CN1 : (Connector type : 40pin / 0.5mm pitch / Bottom contact) : 089N40-000R00-G2

Pin NO.	SYMBOL	DESCRIPTION
1	AV _{SS}	Ground
2	AV _{SS}	Ground
3	ADJ	Brightness control for LED B/L
4	VLED	Power Supply for LED Driver circuit
5	VLED	Power Supply for LED Driver circuit
6	VLED	Power Supply for LED Driver circuit
7	VCC	Power Supply
8	VCC	Power Supply
9	DE	Data Enable Signal
10	AV _{SS}	Ground
11	AV _{SS}	Ground
12	AV _{SS}	Ground
13	B5	Blue Data 5 (MSB)
14	B4	Blue Data 4
15	B3	Blue Data 3
16	V _{SS}	Ground
17	B2	Blue Data 2
18	B1	Blue Data 1
19	B0	Blue Data 0 (LSB)
20	AV _{SS}	Ground
21	G5	Green Data 5 (MSB)
22	G4	Green Data 4
23	G3	Green Data 3
24	AV _{SS}	Ground
25	G2	Green Data 2
26	G1	Green Data 1
27	G0	Green Data 0 (LSB)
28	AV _{SS}	Ground
29	R5	Red Data 5 (MSB)
30	R4	Red Data 4
31	R3	Red Data 3
32	AV _{SS}	Ground
33	R2	Red Data 2
34	R1	Red Data 1
35	R0	Red Data 0
36	AV _{SS}	Ground
37	AV _{SS}	Ground
38	DCLK	Clock Signal
39	AV _{SS}	Ground
40	AV _{SS}	Ground

Remarks:

1). The ADJ can adjust LED BL brightness , where Duty and Luminance are in direct ratio.



2) The ADJ adjust signal level is 0~3.3V , operation frequency:20±5KHz

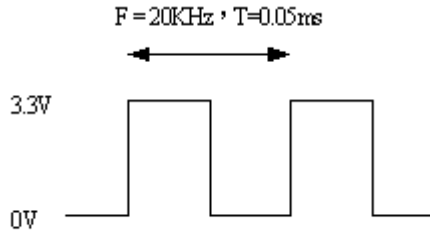

3) AVSS Pin must connection to ground.

DATA MODUL Only Confidential

5. INPUT SIGNAL(DE ONLY MODE)

5.1 Timing Specification

	ITEM	SYMBOL	MIN.	TYP.	MAX.	UNIT		
DCLK	Dot Clock	$1/t_{CLK}$	25	27	32	MHz		
	Low Level Width	t_{WCL}	6	-	-	ns		
	High Level Width	t_{WCH}	6	-	-			
DE	Setup Time	t_{DES}	5	-	-	ns		
	Hold time	t_{DEH}	10	-	-			
	Horizontal Period	t_H	850	900	950	t_{CLK}		
	Horizontal Valid	t_{HA}		800				
	Horizontal Blank	t_{HB}	50	100	150			
		Vertical Period	t_V	490	500	520	t_{HP}	
		Vertical Valid	t_{VA}		480			
		Vertical Blank	t_{VB}	10	20	40		
		Vertical Frequency	f_V	55	60	65		Hz
		Setup Time	t_{DS}	5	-	-		ns
Hold Time	t_{DH}	10	-	-				

【Note1】 This module is operated by DE only mode.

5.2 Timing sequence(Timing chart)

5.2.1 Horizontal Timing Sequence

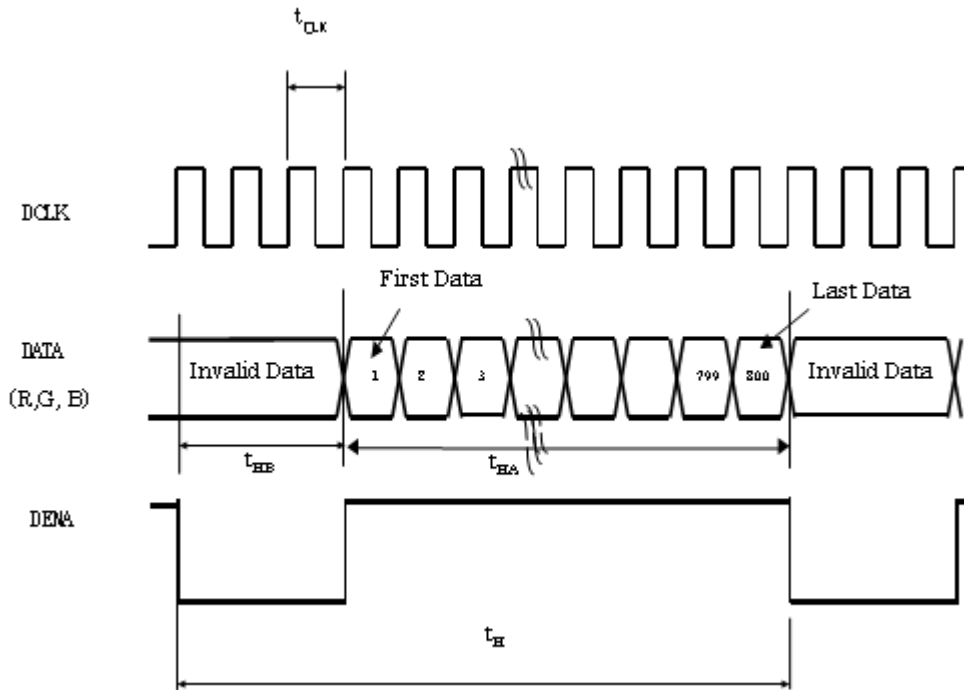

5.2.2 Vertical Timing Sequence

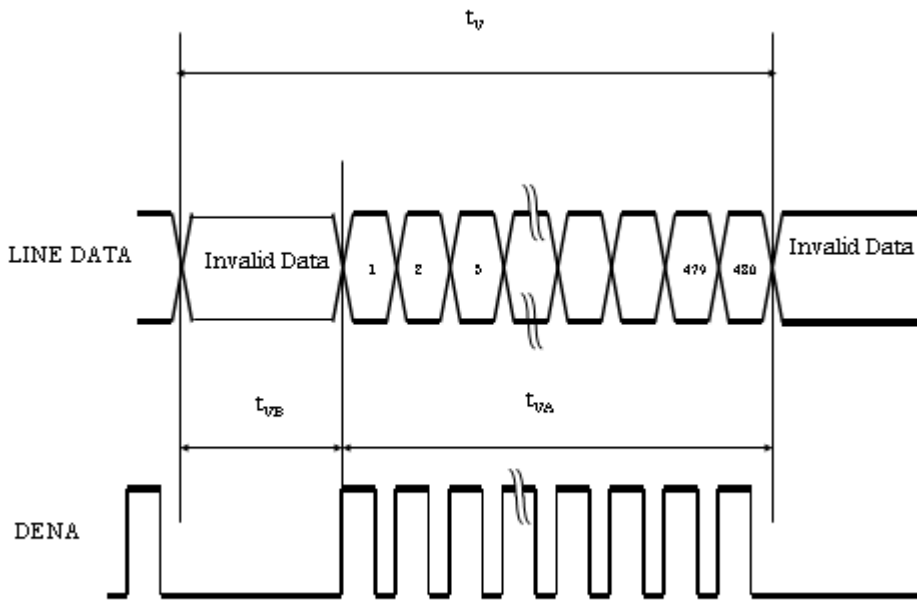

5.3 Color Data Assignment

COLOR	INPUT DATA	R DATA						G DATA						B DATA					
		R5	R4	R3	R2	R1	R0	G5	G4	G3	G2	G1	G0	B5	B4	B3	B2	B1	B0
		MSB					LSB	MSB					LSB	MSB					LSB
BASIC COLOR	BLACK	0	0	0	0	0	0	0	0	0	0	0	0	0	0	0	0	0	0
	RED(63)	1	1	1	1	1	1	0	0	0	0	0	0	0	0	0	0	0	0
	GREEN(63)	0	0	0	0	0	0	1	1	1	1	1	1	0	0	0	0	0	0
	BLUE(63)	0	0	0	0	0	0	0	0	0	0	0	0	1	1	1	1	1	1
	CYAN	0	0	0	0	0	0	1	1	1	1	1	1	1	1	1	1	1	1
	MAGENTA	1	1	1	1	1	1	0	0	0	0	0	0	1	1	1	1	1	1
	YELLOW	1	1	1	1	1	1	1	1	1	1	1	1	0	0	0	0	0	0
	WHITE	1	1	1	1	1	1	1	1	1	1	1	1	1	1	1	1	1	1
RED	RED(0)	0	0	0	0	0	0	0	0	0	0	0	0	0	0	0	0	0	0
	RED(1)	0	0	0	0	0	1	0	0	0	0	0	0	0	0	0	0	0	0
	RED(2)	0	0	0	0	1	0	0	0	0	0	0	0	0	0	0	0	0	0
	RED(62)	1	1	1	1	1	0	0	0	0	0	0	0	0	0	0	0	0	0
	RED(63)	1	1	1	1	1	1	0	0	0	0	0	0	0	0	0	0	0	0
GREEN	GREEN(0)	0	0	0	0	0	0	0	0	0	0	0	0	0	0	0	0	0	0
	GREEN(1)	0	0	0	0	0	0	0	0	0	0	1	0	0	0	0	0	0	0
	GREEN(2)	0	0	0	0	0	0	0	0	0	0	1	0	0	0	0	0	0	0
	GREEN(62)	0	0	0	0	0	0	1	1	1	1	1	0	0	0	0	0	0	0
	GREEN(63)	0	0	0	0	0	0	1	1	1	1	1	1	0	0	0	0	0	0
BLUE	BLUE(0)	0	0	0	0	0	0	0	0	0	0	0	0	0	0	0	0	0	0
	BLUE(1)	0	0	0	0	0	0	0	0	0	0	0	0	0	0	0	0	0	1
	BLUE(2)	0	0	0	0	0	0	0	0	0	0	0	0	0	0	0	0	1	0
	BLUE(62)	0	0	0	0	0	0	0	0	0	0	0	0	1	1	1	1	1	0
	BLUE(63)	0	0	0	0	0	0	0	0	0	0	0	0	1	1	1	1	1	1

Remarks:

- (1)Definition of Gray Scale
 color(n) : n is series of Gray Scale
 The more n value is, the bright Gray Scale.
- (2)Data:1-High,0-Low

7. BLOCK DIAGRAM

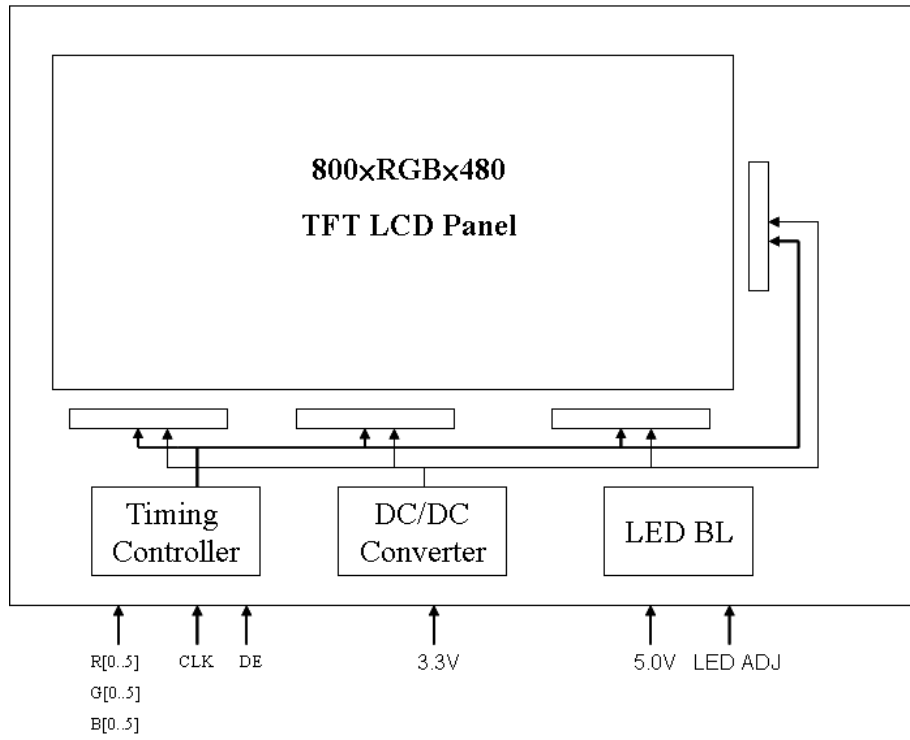

8. MECHANICAL DIMENSION

8.1 Front Side

[Unit : mm]

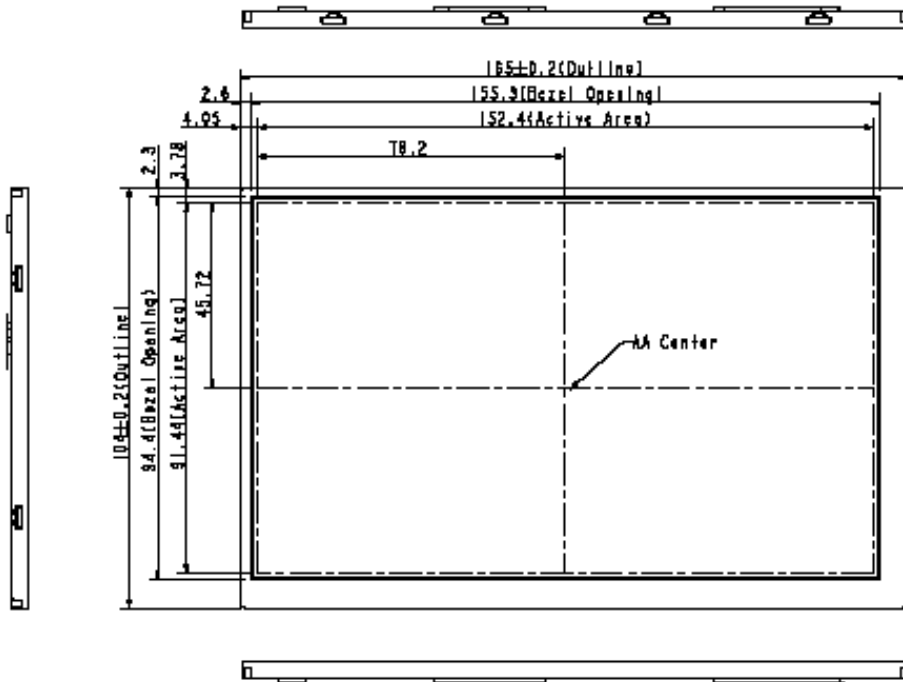

Remark : Un-indication tolerance is ±0.3mm

8.2 Rear Side

[Unit : mm]

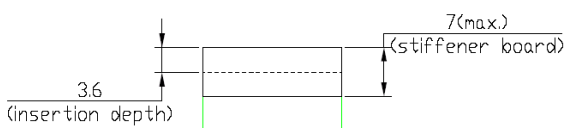
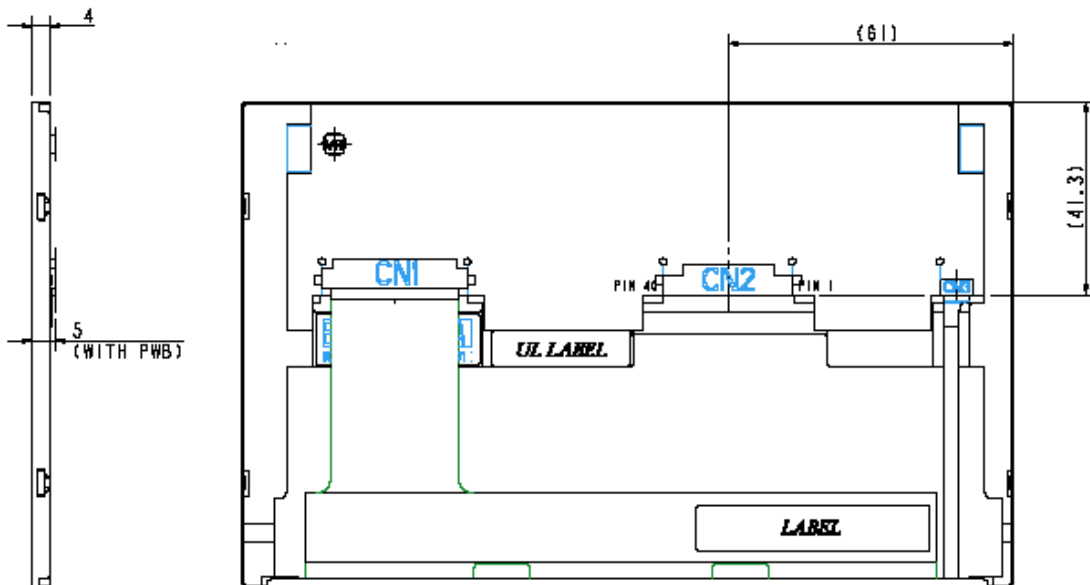

Remark : Un-indication tolerance is ±0.3mm

9. OPTICAL CHARACTERISTICS

ITEM		SYMBOL	CONDITION	MIN.	TYP.	MAX.	UNIT	Remarks
Constrast Ratio		CR	Point-5	300	400	--	--	*1)*2)*3)
Luminance*)		Lw	Point-5	176	220	--	cd/m ²	*1)*3)
Luminance Uniformity		ΔL		70	80	--	%	*1)*3)
Response Time (White - Black)		Tr + Tf	Point-5	--	20	30	ms	*1)*3)*5)
Viewing Angle	Horizontal	ϕ	CR 10 Point-5	120	140	--	°	*1)*2)*4)
	Vertical	θ		90	110	--	°	*1)*2)*4)
Color Coordinate	White	Wx Wy	Point-5	0.273 0.289	0.313 0.329	0.353 0.369	--	*1)*3)
	Red	Rx Ry		0.535 0.292	0.575 0.332	0.615 0.372		
	Green	Gx Gy		0.290 0.525	0.330 0.565	0.370 0.605		
	Blue	Bx By		0.110 0.080	0.150 0.120	0.190 0.160		

Remarks :

*1)Measure condition : 25 ±2 , 60±10%RH , under10 Lux in the dark room.BM-5A (TOPCON) , viewing angle2° , VCC=3.3V , Vadj=3.3V. (Duty=100%) , test the panel after turning on10 minute ago.

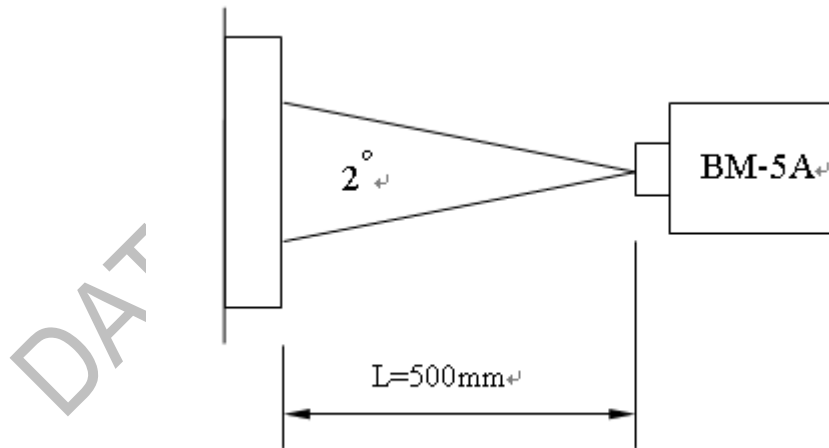

*2) Definition of contrast ratio : (in the dark room.BM-5A (TOPCON))

Contrast Ratio (CR)= (White) Luminance of ON ÷ (Black) Luminance of OFF

*3) Definition of luminance : (in the dark room.BM-5A (TOPCON))

Measure white luminance on the point 5 as figure9-1

Definition of Luminance Uniformity:

Measure white luminance on the point1~9 as figure9-1

$$L = [L(\text{MIN})/L(\text{MAX})] \times 100$$

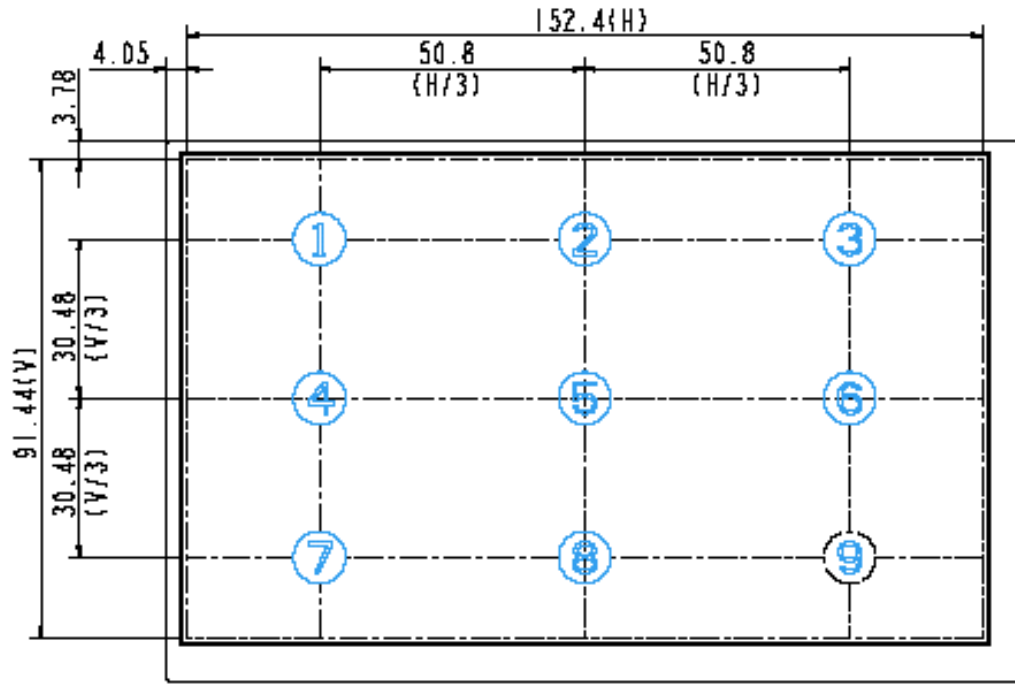

Fig9-1 Measuring point

*4) Definition of Viewing Angle(θ, ψ), refer to Fig9-2 as below : (in the dark room.EZ-CONTRAST (ELDIM))

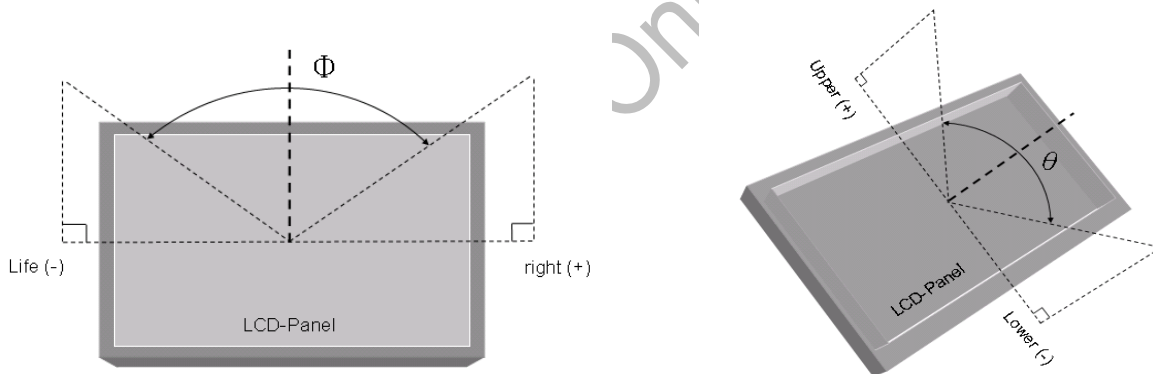

Fig9-2 Definition of Viewing Angle

*5) Definition of Response Time.(White-Black)

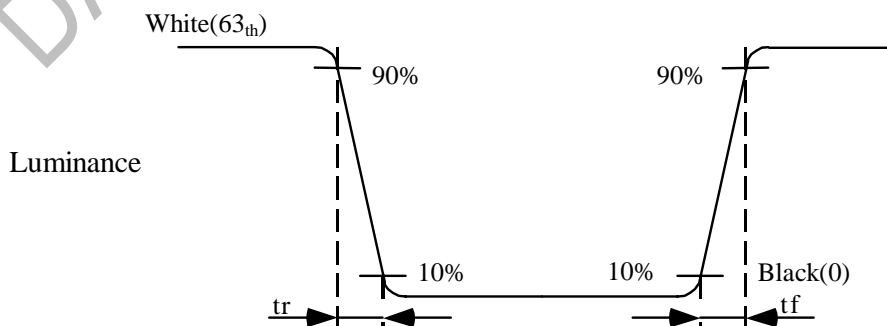

Fig9-3 Definition of Response Time(White-Black)

10. RELIABILITY TEST

10.1. Temperature and humidity

TEST ITEMS	CONDITIONS	REMARK
High Temperature Operation	85°C , 240Hrs	
High Temperature Storage	95°C , 240Hrs	
High Temperature High Humidity Operation	60°C , 90%RH , 240Hrs	No condensation
Low Temperature Operation	-30°C , 240Hrs	
Low Temperature Storage	-40°C , 240Hrs	
Thermal Shock	-30°C (0.5Hr) ~ 85°C(0.5Hr) 200 cycles	

10.2. Shock and Vibration

TEST ITEMS	CONDITIONS
Shock (Non-operation)	<ul style="list-style-type: none"> ● Shock level:980m/s²(equal to 100G) ● Waveform:half sinusoidal wave,6ms. ● Number of shocks:one shock input in each direction of three mutually perpendicular axes for a total of three shock inputs.
Vibration (Non-operation)	<ul style="list-style-type: none"> ● Frequency range:8~33.3Hz ● Stroke:1.3mm ● Vibration:sinusodial wave,perpendicularaxis(both x, z axis:2Hrs, y axis 4Hrs). ● Sweep:2.9G,33.3Hz-400Hz ● Cycle:15min

10.3 Electrostatic Discharge

TEST ITEMS	CONDITIONS	Note
ESD	150pF , 330Ω , ±15kV air test	(1)
	200pF , 0Ω , 200V contact test	(2)

[Note]

Measure point : (1) LCD glass and metal bezel..
(2) IF connector pins

10.4 MTBF : with LED B/L:20000Hrs lifetimes

10.5 Judgment standard

The Judgment of the above test should be made as follow:

Pass:Normal display image with no obvious non-uniformity and no line defect.Partial transformation of the module parts should be ignored.

Fail:No display image,obvious non-uniformity,or line defect.