

POWERTIP

Specification

5,7" TFT

PH320240T-009-IC1Q
(compatible to Kyocera and Sharp)

Version September 2007

Contents

1. SPECIFICATIONS

- 1.1 Features
- 1.2 Mechanical Specifications
- 1.3 Absolute Maximum Ratings
- 1.4 DC Electrical Characteristics
- 1.5 Optical Characteristics
- 1.6 Backlight Characteristics

2. MODULE STRUCTURE

- 2.1 Counter Drawing
- 2.2 Interface Pin Description
- 2.3 Timing Characteristics
- 2.4 JUMPER(Setting different use)

3. QUALITY ASSURANCE SYSTEM

- 3.1 Quality Assurance Flow Chart
- 3.2 Inspection Specification

4. RELIABILITY TEST

- 4.1 Reliability Test Condition

5. PRECAUTION RELATING PRODUCT HANDLING

- 5.1 Safety
- 5.2 Handling
- 5.3 Storage
- 5.4 Terms of Warranty

Appendix : LCM Drawing Packaging

Note : For detailed information please refer to IC data sheet :

Primacy(TFT LCD): Himax: HX8218-A + HX8615A
(Or compatible IC)

1. SPECIFICATIONS

1.1 Features

Main LCD panel

Item	Standard Value
Display Type	320(R、 G、 B) * 240 Dots
LCD Type	Normally white , Transmissive type
Screen size(inch)	5.7 inch
Viewing Direction	6 O'clock
Color configuration	RGB-Strip
Backlight	LED
Interface	Digital 18-bits RGB
Other(controller/driver IC)	Himax: HX8218-A + HX8615A (Or compatible IC)
ROHS	THIS PRODUCT is ROHS CONFORM

1.2 Mechanical Specifications

Item	Standard Value	Unit
Outline Dimension	144.0(W) x 104.6 (L) x 13.0 (H)	mm

LCD panel

Item	Standard Value	Unit
Viewing Area	116.2 (W) x 87.4 (H)	mm
Active Area	115.2 (W) x 86.4 (L)	mm

Note : For detailed information please refer to LCM drawing

1.3 Absolute Maximum Ratings

Module

Item	Symbol	Condition	Min.	Max.	Unit
System Power Supply Voltage	VDD	GND=0	-0.3	7.0	V
Input Voltage	V _i	-	-0.3	VDD+0.3	V
Operating Temperature	T _{OP}	-	-20	70	°C
Storage Temperature	T _{ST}	-	-30	80	°C

1.4 DC Electrical Characteristics

Module

Gnd = 0V , Ta = 25°C

Item	Symbol	Condition	Min.	Typ.	Max.	Unit
Analog Supply Voltage	VDD	-	3	3.3	3.6	V
Analog Operation Current	IDD	VDD = 3.3V Pattern=full display	-	75	-	mA
		VDD = 3.3V Pattern= black *1		75	125	

Note1:Maximum current display

1.5 Optical Characteristics

TFT LCD Module

VDD=3.3V, Ta=25°C

Item		Symbol	Condition	Min.	Typ.	Max.	unit	-
Response time	Rise	Tr	Ta = 25°C θX, θY = 0°	-	15	30	ms	Note2
	Fall	Tf		-	35	50		
Viewing angle	Top	θY+	CR ≥ 10	45	-	-	Deg.	Note4
	Bottom	θY-		50	-	-		
	Left	θX-		50	-	-		
	Right	θX+		50	-	-		
Contrast ratio		CR	Ta = 25°C θX, θY = 0°	150	250	-	-	Note3
Color of CIE Coordinate (With B/L)	White	X	-	0.250	0.300	0.350	-	Note A
		Y		0.267	0.317	0.367		
	Red	X		0.571	0.621	0.671		
		Y		0.311	0.361	0.411		
	Green	X		0.281	0.331	0.381		
		Y		0.524	0.574	0.624		
	Blue	X		0.092	0.142	0.192		
		Y		0.036	0.086	0.136		
Average Brightness Pattern=white display (With B/L)		IV	IF=75 mA	230	255	-	cd/m ²	
Uniformity (With B/L)*1		B		70	-	-	%	

Note A:

*1 : $B = B(\min) / B(\max)$

*2 : Measurement Condition for Optical Characteristics:

a : Environment: 25 ±5 / 60±20%R.H , no wind , dark room below 10 Lux at typical lamp current and typical operating frequency.

b : Measurement Distance: 500 ± 50 mm , (θ= 0°)

c : Equipment: TOPCON BM-7 fast , (field 1°) , after 10 minutes operation.

d : The uncertainty of the C.I.E coordinate measurement ±0.01 , Average Brightness ± 4%

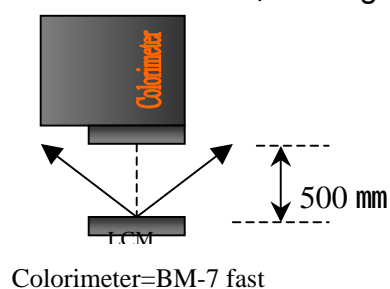
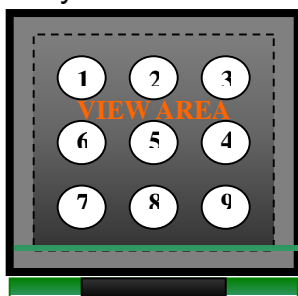

Note1: To be measured at the center area of panel with a viewing cone of 1° by Topcon luminance meter BM-7, after 10 minutes operation (module)

Note2: Definition of response time:

The output signals of photo detector are measured when the input signals are changed from “black” to “white”(falling time) and from “white” to “black”(rising time), respectively. The response time is defined as the time interval between the 10% and 90% of Amplitudes.

Refer to figure as below:

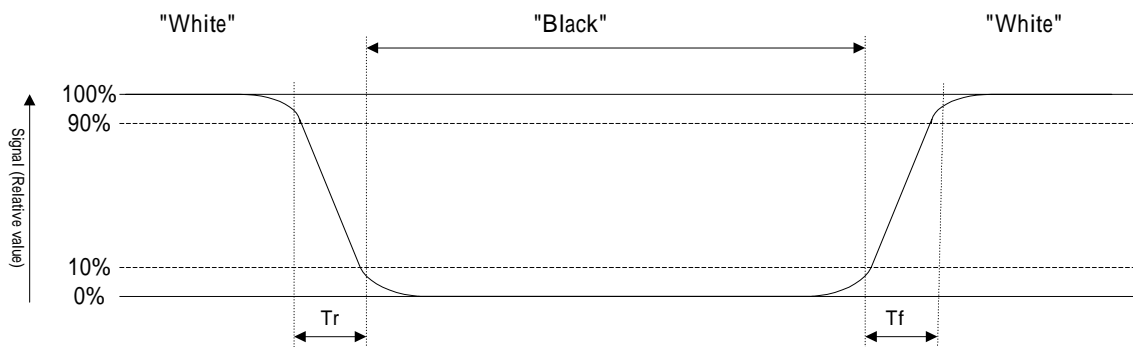

Note3: Definition of contrast ratio:

Contrast ratio is calculated with the following formula

$$\text{Contrast ratio (CR)} = \frac{\text{Photo detector output when LCD is at "White" state}}{\text{Photo detector output when LCD is at "Black" state}}$$

Note4: Definition of viewing angle:

Refer to figure as below:

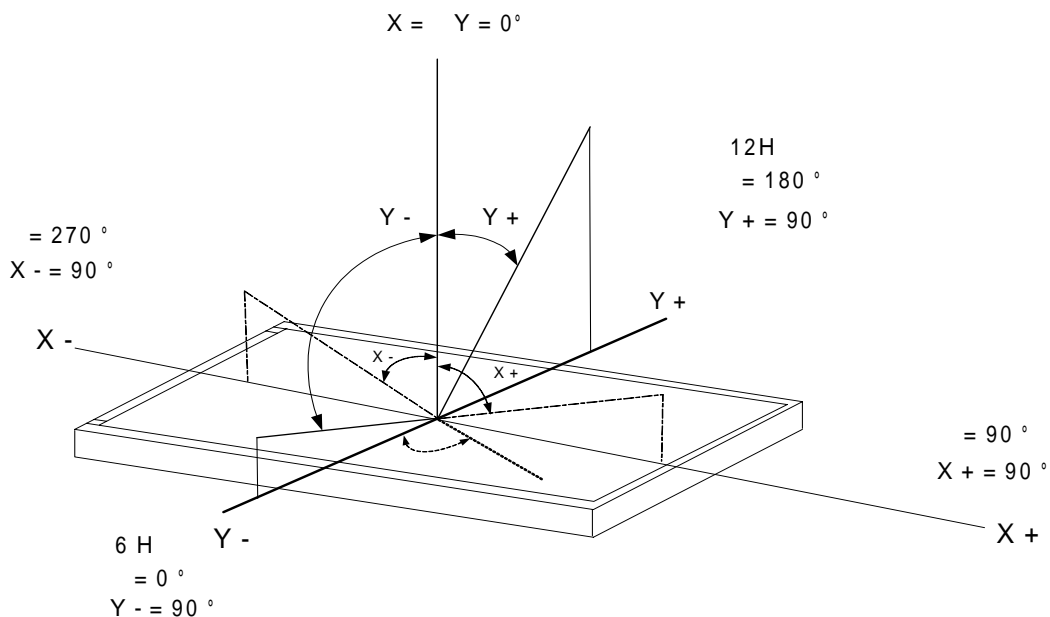

1.6 Backlight Characteristics

Maximum Ratings

Item	Symbol	Conditions	Min.	Max.	Unit
Reverse Voltage	VR	Ta =25	-	35	V

Electrical / Optical Characteristics

Item	Symbol	Conditions	Min.	Typ.	Max.	Unit
Forward Voltage	VF	IF= 25 mA /one line*1	23.0	23.5	24.0	V
Average Brightness (without LCD)	IV		2700	3000	-	cd/m ²
CIE Color Coordinate (Without LCD)	X		0.290			-
	Y		0.290			
Color	White					

Note 1 : For each one line : “AN1-CA1”, “AN2-CA2”, “AN3-CA3”.

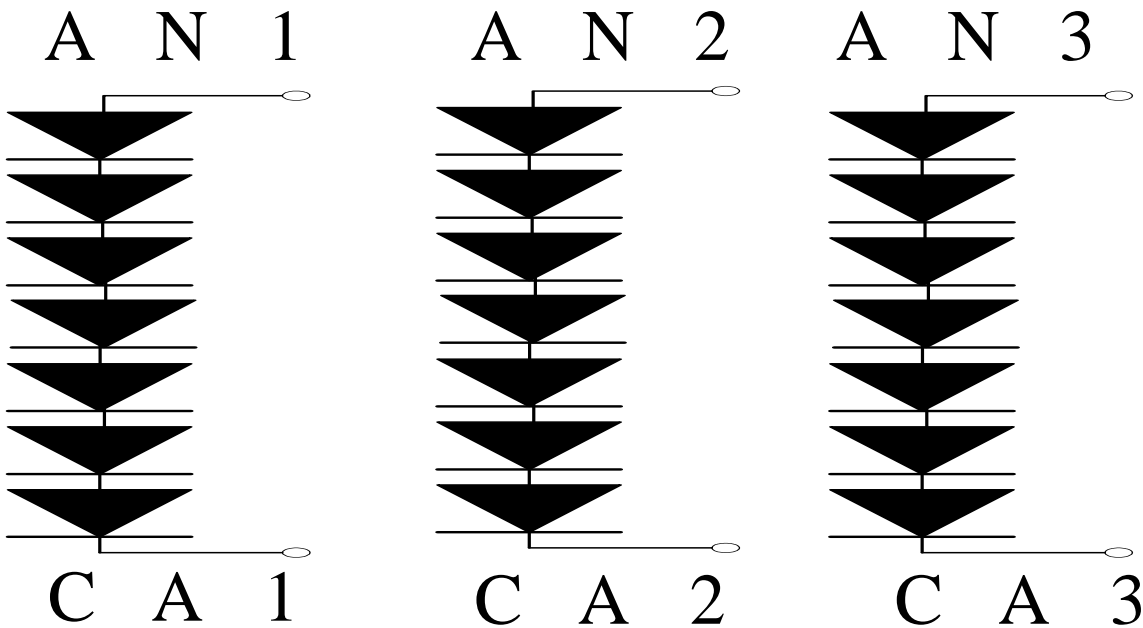

2. MODULE STRUCTURE

2.1 Counter Drawing

2.1.1 LCM Mechanical Diagram

* See Appendix

2.1.2 Block Diagram

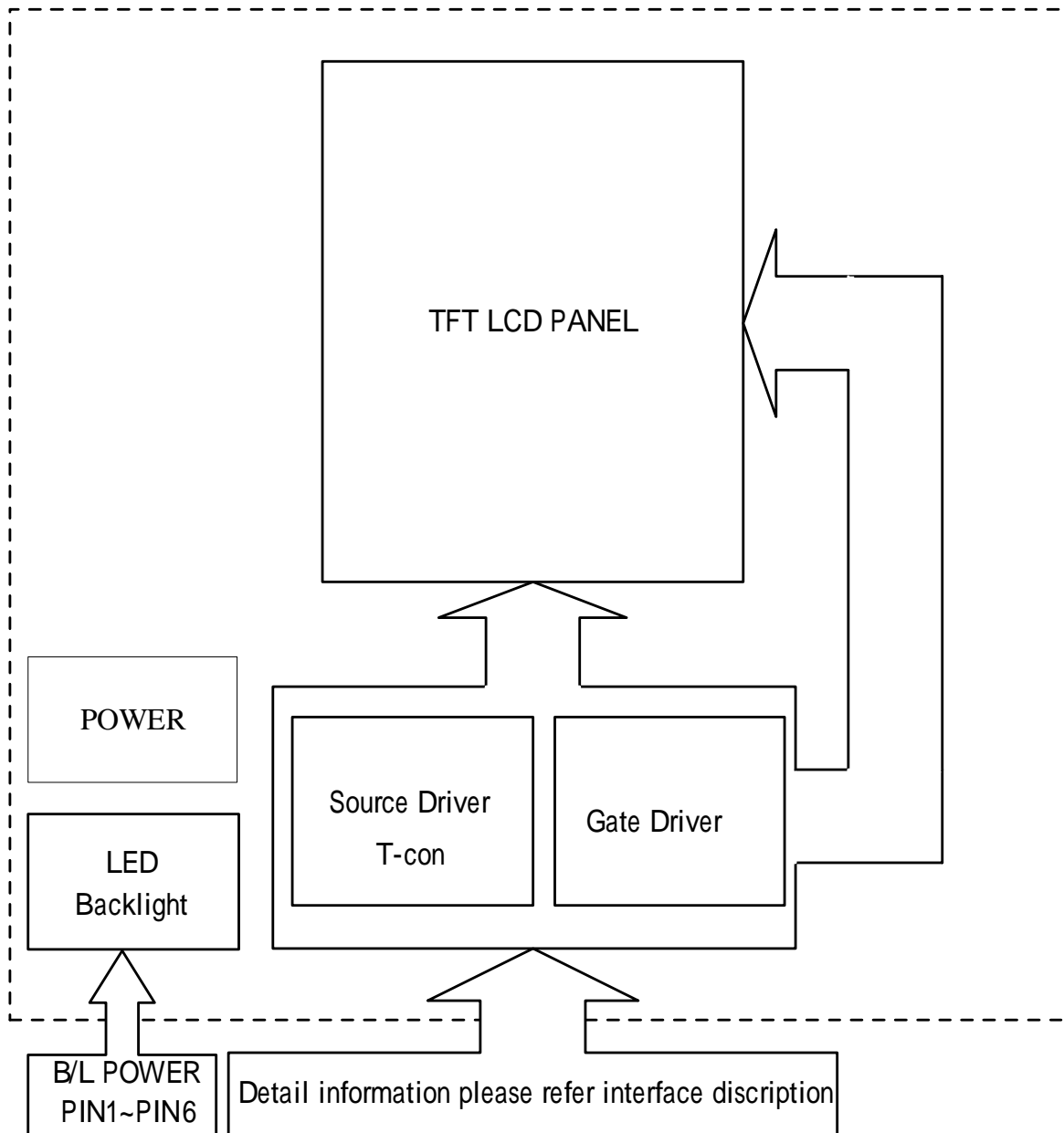

2.2 Interface Pin Description

Pin No.	Symbol	Function
1	GND	GND
2	CK	Clock signal for sampling each data signal
3	HSYNC	Horizontal sync input
4	VSYNC	Vertical sync input
5	GND	GND
6	R0	RED data signal (LSB)
7	R1	RED data signal
8	R2	RED data signal
9	R3	RED data signal
10	R4	RED data signal
11	R5	RED data signal (MSB)
12	GND	GND
13	G0	GREEN data signal (LSB)
14	G1	GREEN data signal
15	G2	GREEN data signal
16	G3	GREEN data signal
17	G4	GREEN data signal
18	G5	GREEN data signal (MSB)
19	GND	GND
20	B0	BLUE data signal (LSB)
21	B1	BLUE data signal
22	B2	BLUE data signal
23	B3	BLUE data signal
24	B4	BLUE data signal
25	B5	BLUE data signal (MSB)
26	GND	GND
27	ENB	Data enable control
28	VDD	3.3V power supply
29	VDD	3.3V power supply
30	R/L	Horizontal display mode select signal L : Normal , H : Left / Right reverse mode

Interface Pin Description(CONT.)

31	U/D	Vertical display mode select signal H : Normal , L : Up / Down reverse mode
32	NC	No Use.
33	GND	GND

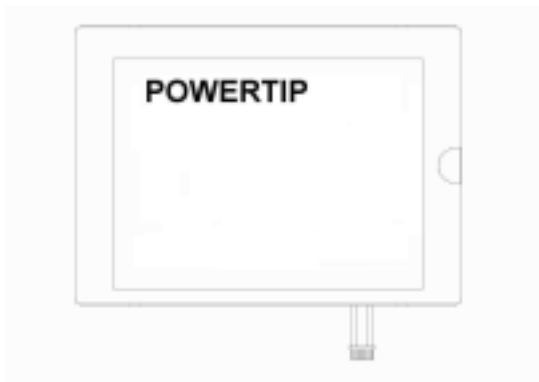

R/L = L
U/D = H



R/L = H
U/D = H



R/L = L
U/D = L



R/L = H
U/D = L

B/L Pin Description

1	AN1	Anode 1
2	AN2	Anode 2
3	AN3	Anode 3
4	CA1	Cathode 1
5	CA2	Cathode 2
6	CA3	Cathode 3

2.3 Timing Characteristics

Signal	Item		Symbol	Min.	Typ.	Max.	Unit
Dclk	Frequency		Dclk		6.4		MHz
	High Time		Tch		78		ns
	Low Time		Tcl		78		ns
Data	Setup Time		Tds	12			ns
	Hold Time		Tdh	12			ns
Hsync	Period		TH		408		DCLK
	Pulse Width		Thp		30		DCLK
	Back-Porch		Thb		38		DCLK
	Display Period		Thd		320		DCLK
	Front-Porch		Thf		20		DCLK
Vsync	Period	NTSC	Tv		262.5		TH
		PAL		312.5			
	Pulse Width		Tvp	1	3	5	TH
	Back-Porch	NTSC	Tvb		15		TH
		PAL		23			
	Display Period		Tvd		240		TH
	Front-Porch	NTSC	Tvf		4.5		TH
		PAL		46.5			

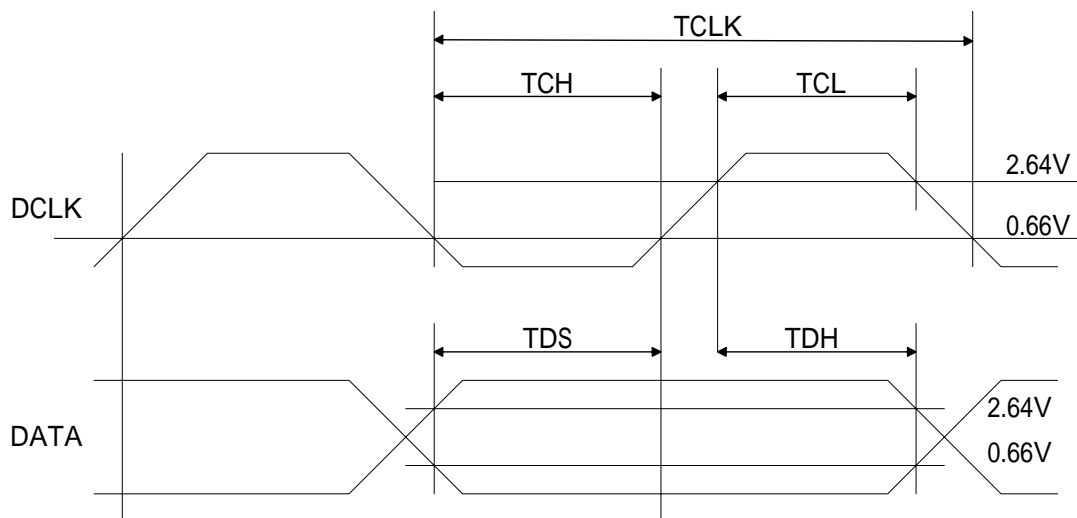

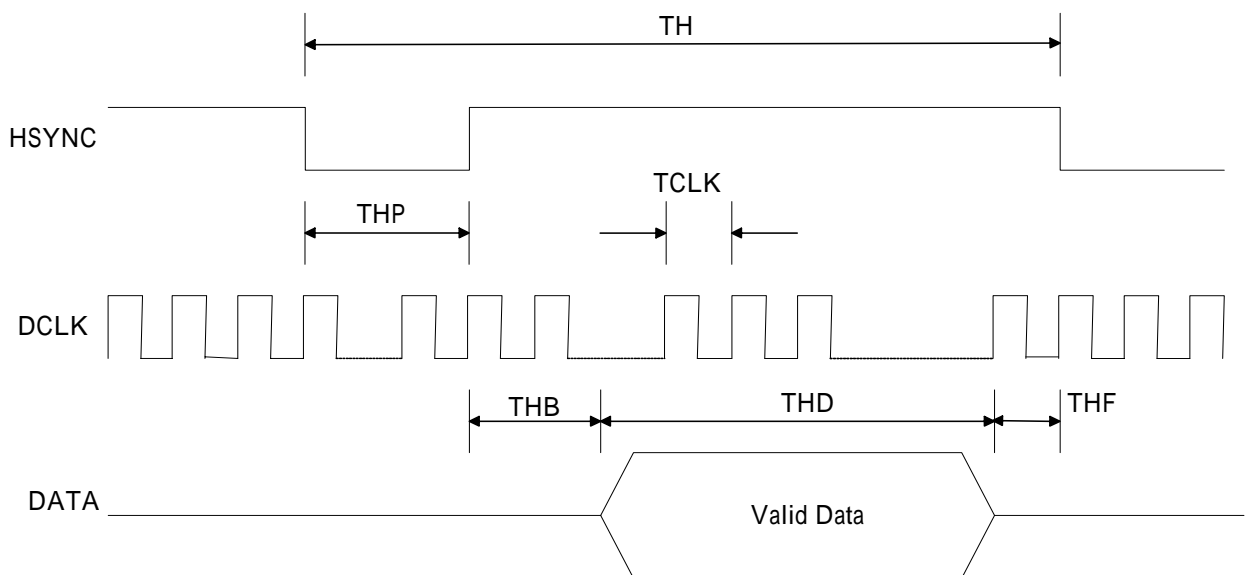
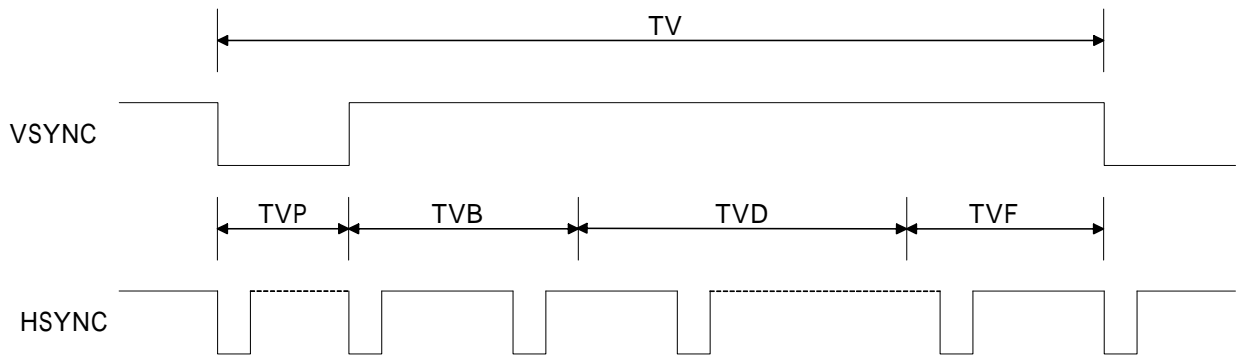
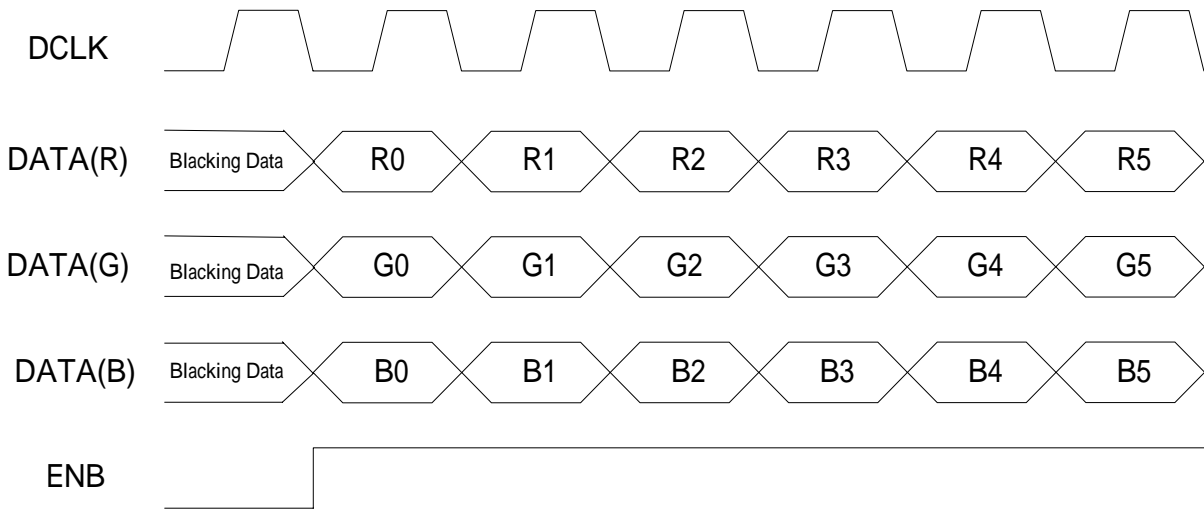

Color Data Assignment

COLOR	INPUT DATA	R DATA						G DATA						B DATA					
		R5	R4	R3	R2	R1	R0	G5	G4	G3	G2	G1	G0	B5	B4	B3	B2	B1	B0
		MSB					LSB	MSB					LSB	MSB					LSB
	BLACK	0	0	0	0	0	0	0	0	0	0	0	0	0	0	0	0	0	0
	RED(63)	1	1	1	1	1	1	0	0	0	0	0	0	0	0	0	0	0	0
BASIC	GREEN(63)	0	0	0	0	0	0	1	1	1	1	1	1	0	0	0	0	0	0
COLOR	BLUE(63)	0	0	0	0	0	0	0	0	0	0	0	0	1	1	1	1	1	1
	CYAN	0	0	0	0	0	0	1	1	1	1	1	1	1	1	1	1	1	1
	MAGENTA	1	1	1	1	1	1	0	0	0	0	0	0	1	1	1	1	1	1
	YELLOW	1	1	1	1	1	1	1	1	1	1	1	1	0	0	0	0	0	0
	WHITE	1	1	1	1	1	1	1	1	1	1	1	1	1	1	1	1	1	1
	RED(0)	0	0	0	0	0	0	0	0	0	0	0	0	0	0	0	0	0	0
	RED(1)	0	0	0	0	0	1	0	0	0	0	0	0	0	0	0	0	0	0
	RED(2)	0	0	0	0	1	0	0	0	0	0	0	0	0	0	0	0	0	0
RED																			
	RED(62)	1	1	1	1	1	0	0	0	0	0	0	0	0	0	0	0	0	0
	RED(63)	1	1	1	1	1	1	0	0	0	0	0	0	0	0	0	0	0	0
	GREEN(0)	0	0	0	0	0	0	0	0	0	0	0	0	0	0	0	0	0	0
	GREEN(1)	0	0	0	0	0	0	0	0	0	0	0	1	0	0	0	0	0	0
	GREEN(2)	0	0	0	0	0	0	0	0	0	0	1	0	0	0	0	0	0	0
GREEN																			
	GREEN(62)	0	0	0	0	0	0	1	1	1	1	1	0	0	0	0	0	0	0
	GREEN(63)	0	0	0	0	0	0	1	1	1	1	1	1	0	0	0	0	0	0
	BLUE(0)	0	0	0	0	0	0	0	0	0	0	0	0	0	0	0	0	0	0
	BLUE(1)	0	0	0	0	0	0	0	0	0	0	0	0	0	0	0	0	0	1
	BLUE(2)	0	0	0	0	0	0	0	0	0	0	0	0	0	0	0	0	1	0
BLUE																			
	BLUE(62)	0	0	0	0	0	0	0	0	0	0	0	0	1	1	1	1	1	0
	BLUE(63)	0	0	0	0	0	0	0	0	0	0	0	0	1	1	1	1	1	1

Remarks :

(1) Definition of Gray Scale

color(n) : n is series of Gray Scale

The more n value is, the bright Gray Scale.

(2)Data: 1-High,0-Low

2.4 JUMPER(Setting different use) (J1-2,J2-1,J3-2)

3. QUALITY ASSURANCE SYSTEM

3.1 Quality Assurance Flow Chart

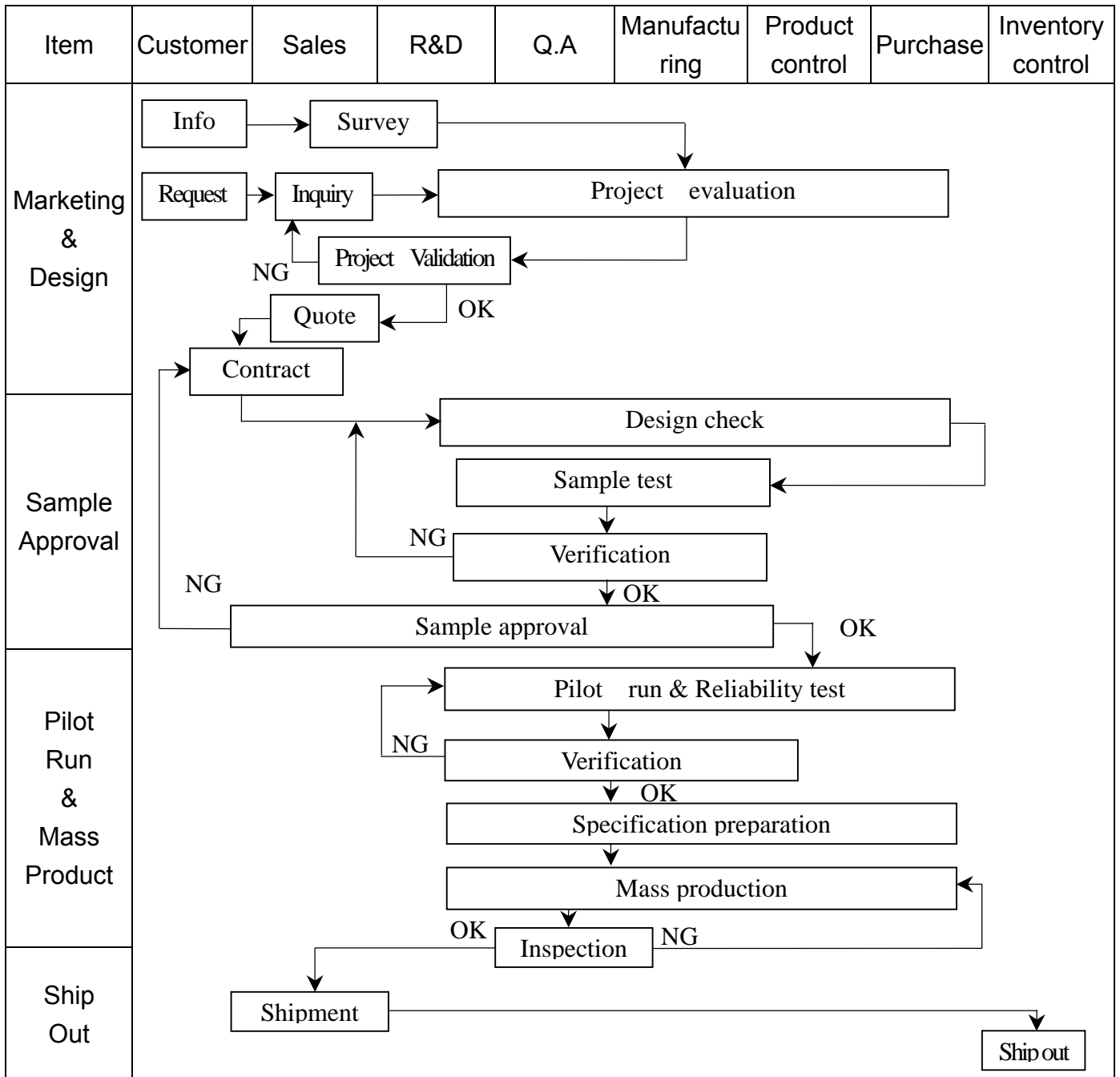

Item	Customer	Sales	R&D	Q.A	Manufacturing	Product control	Purchase	Inventory control
Sales Service	<pre> graph TD Info[Info] --> Claim[Claim] Claim --> Failure[Failure analysis] Failure --> Report[Analysis report] Failure --> Action[Corrective action] Action --> Tracking[Tracking] </pre>							
Q.A Activity	1. ISO 9001 Maintenance Activities 3. Equipment calibration 5. Standardization Management				2. Process improvement proposal 4. Education And Training Activities			

3.2 Inspection Specification

1. Inspection Specification

- ◆Scope : The document shall be applied to TFT-LCD Module for 3.5" ~10" (Ver. 02).
- ◆Inspection Standard : MIL-STD-105E Table Normal Inspection Single Sampling Level II.
- ◆Equipment : Gauge 、 MIL-STD 、 Powertip Tester 、 Sample
- ◆Defect Level : Major Defect AQL : 0.4 ; Minor Defect AQL : 1.5
- ◆OUT Going Defect Level : Sampling.
- ◆Standard of the product appearance test :
 - a. Manner of appearance test :
 - (1). The test best be under 20W×2 fluorescent light , and distance of view must be at 30 cm.
 - (2). The test direction is base on about around 45° of vertical line.

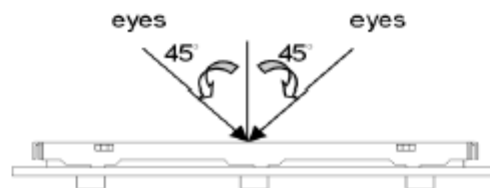

(3). Definition of area.

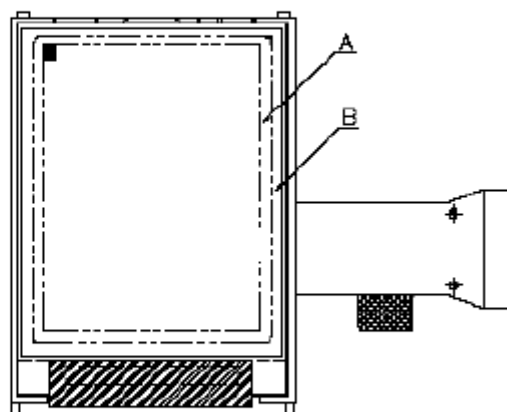

A area : viewing area

B area : Outside of viewing area

(4). Standard of inspection : (Unit : mm)



◆Specification For TFT-LCD Module 3.5" ~10" :

(Ver. 02)

NO	Item	Criterion	Level												
01	Product condition	1. 1 The part number is inconsistent with work order of production.	Major												
		1. 2 Mixed product types.	Major												
		1. 3 Assembled in inverse direction.	Major												
02	Quantity	2. 1 The quantity is inconsistent with work order of production.	Major												
03	Outline dimension	3. 1 Product dimension and structure must conform to structure diagram.	Major												
04	Electrical Testing	4. 1 Missing line character and icon.	Major												
		4. 2 No function or no display.	Major												
		4. 3 Display malfunction.	Major												
		4. 4 LCD viewing angle defect.	Major												
		4. 5 Current consumption exceeds product specifications.	Major												
05	Dot defect (Bright dot 、 Dark dot) On -display	<table border="1" style="margin: auto; border-collapse: collapse;"> <thead> <tr> <th style="width: 10%;"></th> <th style="width: 40%;">Item</th> <th style="width: 50%;">Acceptance (Q'ty)</th> </tr> </thead> <tbody> <tr> <td rowspan="4" style="text-align: center; vertical-align: middle;">Dot Defect</td> <td style="text-align: center;">Bright Dot</td> <td style="text-align: center;">≤ 4</td> </tr> <tr> <td style="text-align: center;">Dark Dot</td> <td style="text-align: center;">≤ 5</td> </tr> <tr> <td style="text-align: center;">Joint Dot</td> <td style="text-align: center;">≤ 3</td> </tr> <tr> <td style="text-align: center;">Total</td> <td style="text-align: center;">≤ 7</td> </tr> </tbody> </table> <p>5. 1 Inspection pattern : full white , full black , Red , Green and blue screens.</p> <p>5. 2 It is defined as dot defect if defect area $> 1/2$ dot.</p> <p>5. 3 The distance between two dot defect ≥ 5 mm.</p>		Item	Acceptance (Q'ty)	Dot Defect	Bright Dot	≤ 4	Dark Dot	≤ 5	Joint Dot	≤ 3	Total	≤ 7	Minor
	Item	Acceptance (Q'ty)													
Dot Defect	Bright Dot	≤ 4													
	Dark Dot	≤ 5													
	Joint Dot	≤ 3													
	Total	≤ 7													

◆Specification For TFT-LCD Module 3.5" ~10" :

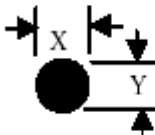
(Ver. 02)

NO	Item	Criterion	Level																												
06	<p>Black or white dot、scratch、contamination</p> <p>Round type</p>  <p>$\Phi = (x + y) / 2$</p> <p>Line type</p> 	<p>6. 1 Round type (Non-display or display) :</p> <table border="1" style="width: 100%; margin: 10px 0;"> <thead> <tr> <th>Dimension (diameter : Φ)</th> <th>Acceptance (Q'ty)</th> </tr> </thead> <tbody> <tr> <td style="text-align: center;">$\Phi \leq 0.25$</td> <td style="text-align: center;">Ignore</td> </tr> <tr> <td style="text-align: center;">$0.25 < \Phi \leq 0.50$</td> <td style="text-align: center;">5</td> </tr> <tr> <td style="text-align: center;">$\Phi > 0.50$</td> <td style="text-align: center;">0</td> </tr> <tr> <td style="text-align: center;">Total</td> <td style="text-align: center;">5</td> </tr> </tbody> </table> <p>6. 2 Line type(Non-display or display) :</p> <table border="1" style="width: 100%; margin: 10px 0;"> <thead> <tr> <th>Length (L)</th> <th>Width (W)</th> <th>Acceptance (Q'ty)</th> </tr> </thead> <tbody> <tr> <td style="text-align: center;">---</td> <td style="text-align: center;">$W \leq 0.03$</td> <td style="text-align: center;">Ignore</td> </tr> <tr> <td style="text-align: center;">$L \leq 10.0$</td> <td style="text-align: center;">$0.03 < W \leq 0.05$</td> <td style="text-align: center;">4</td> </tr> <tr> <td style="text-align: center;">$L \leq 5.0$</td> <td style="text-align: center;">$0.05 < W \leq 0.10$</td> <td style="text-align: center;">2</td> </tr> <tr> <td style="text-align: center;">---</td> <td style="text-align: center;">$W > 0.10$</td> <td style="text-align: center;">As round type</td> </tr> <tr> <td colspan="2" style="text-align: center;">Total</td> <td style="text-align: center;">5</td> </tr> </tbody> </table>	Dimension (diameter : Φ)	Acceptance (Q'ty)	$\Phi \leq 0.25$	Ignore	$0.25 < \Phi \leq 0.50$	5	$\Phi > 0.50$	0	Total	5	Length (L)	Width (W)	Acceptance (Q'ty)	---	$W \leq 0.03$	Ignore	$L \leq 10.0$	$0.03 < W \leq 0.05$	4	$L \leq 5.0$	$0.05 < W \leq 0.10$	2	---	$W > 0.10$	As round type	Total		5	Minor
Dimension (diameter : Φ)	Acceptance (Q'ty)																														
$\Phi \leq 0.25$	Ignore																														
$0.25 < \Phi \leq 0.50$	5																														
$\Phi > 0.50$	0																														
Total	5																														
Length (L)	Width (W)	Acceptance (Q'ty)																													
---	$W \leq 0.03$	Ignore																													
$L \leq 10.0$	$0.03 < W \leq 0.05$	4																													
$L \leq 5.0$	$0.05 < W \leq 0.10$	2																													
---	$W > 0.10$	As round type																													
Total		5																													
07	<p>Polarizer Bubble</p>	<table border="1" style="width: 100%; margin: 10px 0;"> <thead> <tr> <th>Dimension (diameter : Φ)</th> <th>Acceptance (Q'ty)</th> </tr> </thead> <tbody> <tr> <td style="text-align: center;">$\Phi \leq 0.25$</td> <td style="text-align: center;">Ignore</td> </tr> <tr> <td style="text-align: center;">$0.25 < \Phi \leq 0.50$</td> <td style="text-align: center;">4</td> </tr> <tr> <td style="text-align: center;">$0.50 < \Phi \leq 0.80$</td> <td style="text-align: center;">1</td> </tr> <tr> <td style="text-align: center;">$\Phi > 0.80$</td> <td style="text-align: center;">0</td> </tr> <tr> <td style="text-align: center;">Total</td> <td style="text-align: center;">5</td> </tr> </tbody> </table>	Dimension (diameter : Φ)	Acceptance (Q'ty)	$\Phi \leq 0.25$	Ignore	$0.25 < \Phi \leq 0.50$	4	$0.50 < \Phi \leq 0.80$	1	$\Phi > 0.80$	0	Total	5	Minor																
Dimension (diameter : Φ)	Acceptance (Q'ty)																														
$\Phi \leq 0.25$	Ignore																														
$0.25 < \Phi \leq 0.50$	4																														
$0.50 < \Phi \leq 0.80$	1																														
$\Phi > 0.80$	0																														
Total	5																														

◆Specification For TFT-LCD Module 3.5" ~10" :

(Ver. 02)

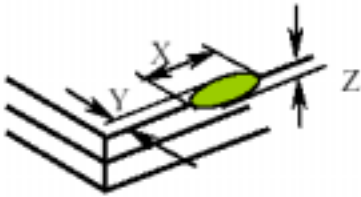
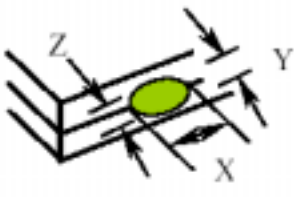
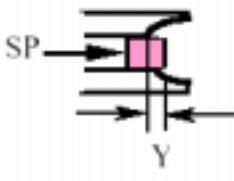
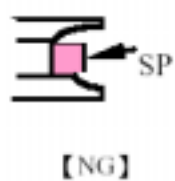
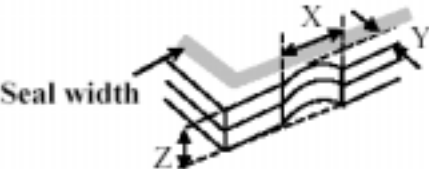
NO	Item	Criterion	Level									
08	The crack of glass	<p>Symbols :</p> <p>X : The length of crack Y : The width of crack. Z : The thickness of crack W : terminal length t : The thickness of glass a : LCD side length</p> <hr style="border-top: 1px dashed black;"/> <p>8.1 General glass chip :</p> <p>8.1.1 Chip on panel surface and crack between panels:</p> <div style="display: flex; justify-content: space-around; align-items: center;"> <div style="text-align: center;">  </div> <div style="text-align: center;">  </div> </div> <div style="display: flex; justify-content: space-around; align-items: center; margin-top: 20px;"> <div style="text-align: center;">  <p>[OK]</p> </div> <div style="text-align: center;">  <p>[NG]</p> </div> </div> <div style="text-align: center; margin-top: 20px;">  </div> <table border="1" style="margin-top: 20px; width: 100%; border-collapse: collapse;"> <thead> <tr> <th style="width: 25%;">X</th> <th style="width: 40%;">Y</th> <th style="width: 35%;">Z</th> </tr> </thead> <tbody> <tr> <td style="text-align: center;">$\leq a$</td> <td style="text-align: center;">Crack can't enter viewing area</td> <td style="text-align: center;">$\leq 1/2 t$</td> </tr> <tr> <td style="text-align: center;">$\leq a$</td> <td style="text-align: center;">Crack can't exceed the half of SP width.</td> <td style="text-align: center;">$1/2 t < Z \leq 2 t$</td> </tr> </tbody> </table>	X	Y	Z	$\leq a$	Crack can't enter viewing area	$\leq 1/2 t$	$\leq a$	Crack can't exceed the half of SP width.	$1/2 t < Z \leq 2 t$	Minor
X	Y	Z										
$\leq a$	Crack can't enter viewing area	$\leq 1/2 t$										
$\leq a$	Crack can't exceed the half of SP width.	$1/2 t < Z \leq 2 t$										

◆ Specification For TFT-LCD Module 3.5" ~10" :

(Ver. 02)

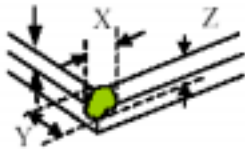
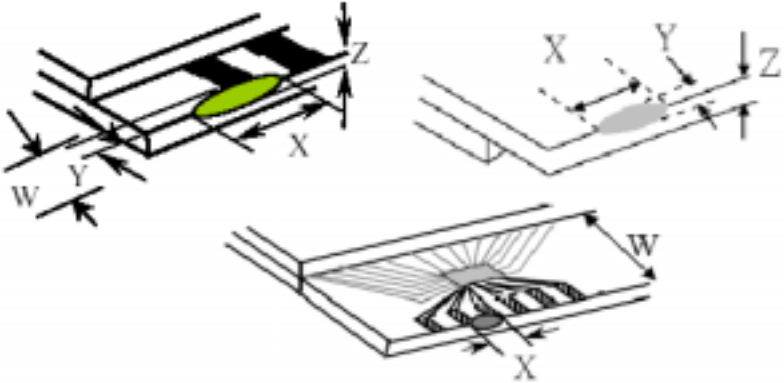
NO	Item	Criterion	Level									
08	The crack of glass	<p>Symbols :</p> <p>X : The length of crack Z : The thickness of crack t : The thickness of glass</p> <p>Y : The width of crack. W : terminal length a : LCD side length</p> <hr style="border-top: 1px dashed black;"/> <p>8.1.2 Corner crack :</p> <div style="text-align: center;">  </div> <table border="1" style="margin: 10px auto; border-collapse: collapse;"> <thead> <tr> <th style="width: 25%;">X</th> <th style="width: 50%;">Y</th> <th style="width: 25%;">Z</th> </tr> </thead> <tbody> <tr> <td style="text-align: center;">$\leq 1/5 a$</td> <td style="text-align: center;">Crack can't enter viewing area</td> <td style="text-align: center;">$Z \leq 1/2 t$</td> </tr> <tr> <td style="text-align: center;">$\leq 1/5 a$</td> <td style="text-align: center;">Crack can't exceed the half of SP width.</td> <td style="text-align: center;">$1/2 t < Z \leq 2 t$</td> </tr> </tbody> </table>	X	Y	Z	$\leq 1/5 a$	Crack can't enter viewing area	$Z \leq 1/2 t$	$\leq 1/5 a$	Crack can't exceed the half of SP width.	$1/2 t < Z \leq 2 t$	Minor
		X	Y	Z								
$\leq 1/5 a$	Crack can't enter viewing area	$Z \leq 1/2 t$										
$\leq 1/5 a$	Crack can't exceed the half of SP width.	$1/2 t < Z \leq 2 t$										
<p>8.2 Protrusion over terminal :</p> <p>8.2.1 Chip on electrode pad :</p> <div style="text-align: center;">  </div> <table border="1" style="margin: 10px auto; border-collapse: collapse;"> <thead> <tr> <th></th> <th style="width: 25%;">X</th> <th style="width: 25%;">Y</th> <th style="width: 25%;">Z</th> </tr> </thead> <tbody> <tr> <td style="text-align: center;">Front</td> <td style="text-align: center;">$\leq a$</td> <td style="text-align: center;">$\leq 1/2 W$</td> <td style="text-align: center;">$\leq t$</td> </tr> <tr> <td style="text-align: center;">Back</td> <td style="text-align: center;">$\leq a$</td> <td style="text-align: center;">$\leq W$</td> <td style="text-align: center;">$\leq 1/2 t$</td> </tr> </tbody> </table>		X	Y	Z	Front	$\leq a$	$\leq 1/2 W$	$\leq t$	Back	$\leq a$	$\leq W$	$\leq 1/2 t$
	X	Y	Z									
Front	$\leq a$	$\leq 1/2 W$	$\leq t$									
Back	$\leq a$	$\leq W$	$\leq 1/2 t$									

◆Specification For TFT-LCD Module 3.5" ~10" :

(Ver. 02)

NO	Item	Criterion	Level
09	Backlight elements	9. 1 Backlight can't work normally.	Major
		9. 2 Backlight doesn't light or color is wrong.	Major
		9. 3 Illumination source flickers when lit.	Major
10	General appearance	10. 1 Pin type 、 quantity 、 dimension must match type in structure diagram.	Major
		10. 2 No short circuits in components on PCB or FPC .	Major
		10. 3 Parts on PCB or FPC must be the same as on the production characteristic chart .There should be no wrong parts , missing parts or excess parts.	Major
		10. 4 Product packaging must the same as specified on packaging specification sheet.	Minor
		10. 5 The folding and peeled off in polarizer are not acceptable.	Minor
		10. 6 The PCB or FPC between B/L assembled distance(PCB or FPC) is ≤ 1.5 mm.	Minor

4. RELIABILITY TEST

4.1 Reliability Test Condition

Ver.02

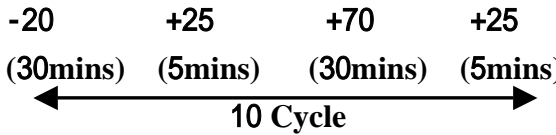
NO.	TEST ITEM	TEST CONDITION											
1	High Temperature Storage Test	Keep in +80 ±2 96 hrs Surrounding temperature, then storage at normal condition 4hrs.											
2	Low Temperature Storage Test	Keep in -30 ±2 96 hrs Surrounding temperature, then storage at normal condition 4hrs.											
3	High Temperature / High Humidity Storage Test	Keep in +60 / 90% R.H duration for 96 hrs Surrounding temperature, then storage at normal condition 4hrs. (Excluding the polarizer)											
4	ESD Test	Air Discharge: Apply 2 KV with 5 times Discharge for each polarity +/-	Contact Discharge: Apply 250 V with 5 times discharge for each polarity +/-										
		1. Temperature ambience : 15 35 2. Humidity relative : 30% 60% 3. Energy Storage Capacitance(Cs+Cd) : 150pF±10% 4. Discharge Resistance(Rd) : 330 ±10% 5. Discharge, mode of operation : Single Discharge (time between successive discharges at least 1 sec) (Tolerance if the output voltage indication : ±5%)											
5	Temperature Cycling Storage Test	-20 +25 +70 +25 (30mins) (5mins) (30mins) (5mins)  Surrounding temperature, then storage at normal condition 4hrs.											
6	Vibration Test (Packaged)	1. Sine wave 10 55 Hz frequency (1 min) 2. The amplitude of vibration :1.5 mm 3. Each direction (X、 Y、 Z) duration for 2 Hrs											
7	Drop Test (Packaged)	<table border="1" data-bbox="746 1668 1343 1944"> <thead> <tr> <th>Packing Weight (Kg)</th> <th>Drop Height (cm)</th> </tr> </thead> <tbody> <tr> <td>0 ~ 45.4</td> <td>122</td> </tr> <tr> <td>45.4 ~ 90.8</td> <td>76</td> </tr> <tr> <td>90.8 ~ 454</td> <td>61</td> </tr> <tr> <td>Over 454</td> <td>46</td> </tr> </tbody> </table> Drop direction : 1 corner / 3 edges / 6 sides each 1times		Packing Weight (Kg)	Drop Height (cm)	0 ~ 45.4	122	45.4 ~ 90.8	76	90.8 ~ 454	61	Over 454	46
Packing Weight (Kg)	Drop Height (cm)												
0 ~ 45.4	122												
45.4 ~ 90.8	76												
90.8 ~ 454	61												
Over 454	46												

5. PRECAUTION RELATING PRODUCT HANDLING

5.1 SAFETY

- 5.1.1 If the LCD panel breaks , be careful not to get the liquid crystal to touch your skin.
- 5.1.2 If the liquid crystal touches your skin or clothes , please wash it off immediately by using soap and water.

5.2 HANDLING

- 5.2.1 Avoid any strong mechanical shock which can break the glass.
- 5.2.2 Avoid static electricity which can damage the CMOS LSI—When working with the module , be sure to ground your body and any electrical equipment you may be using.
- 5.2.3 Do not remove the panel or frame from the module.
- 5.2.4 The polarizing plate of the display is very fragile. So , please handle it very carefully ,do not touch , push or rub the exposed polarizing with anything harder than an HB pencil lead (glass , tweezers , etc.)
- 5.2.5 Do not wipe the polarizing plate with a dry cloth , as it may easily scratch the surface of plate.
- 5.2.6 Do not touch the display area with bare hands , this will stain the display area.
- 5.2.7 Do not use ketonics solvent & aromatic solvent. Use with a soft cloth soaked with a cleaning naphtha solvent.
- 5.2.8 To control temperature and time of soldering is 320 ± 10 and 3-5 sec.
- 5.2.9 To avoid liquid (include organic solvent) stained on LCM .

5.3 STORAGE

- 5.3.1 Store the panel or module in a dark place where the temperature is 25 ± 5 and the humidity is below 65% RH.
- 5.3.2 Do not place the module near organics solvents or corrosive gases.
- 5.3.3 Do not crush , shake , or jolt the module.

5.4 TERMS OF WARRANTY

5.4.1 Applicable warrant period

The period is within thirteen months since the date of shipping out under normal using and storage conditions.

5.4.2 Unaccepted responsibility

This product has been manufactured to your company's specification as a part for use in your company's general electronic products. It is guaranteed to perform according to delivery specifications. For any other use apart from general electronic equipment , we cannot take responsibility if the product is used in nuclear power control equipment , aerospace equipment , fire and security systems or any other applications in which there is a direct risk to human life and where extremely high levels of reliability are required.

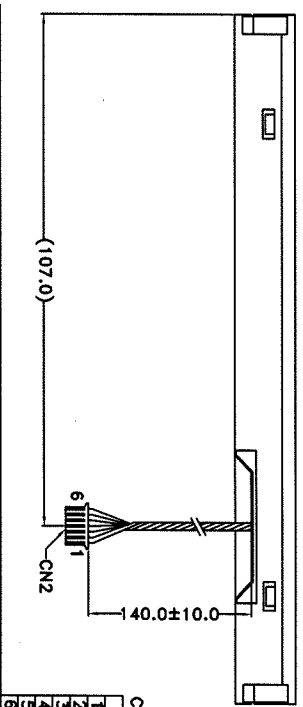
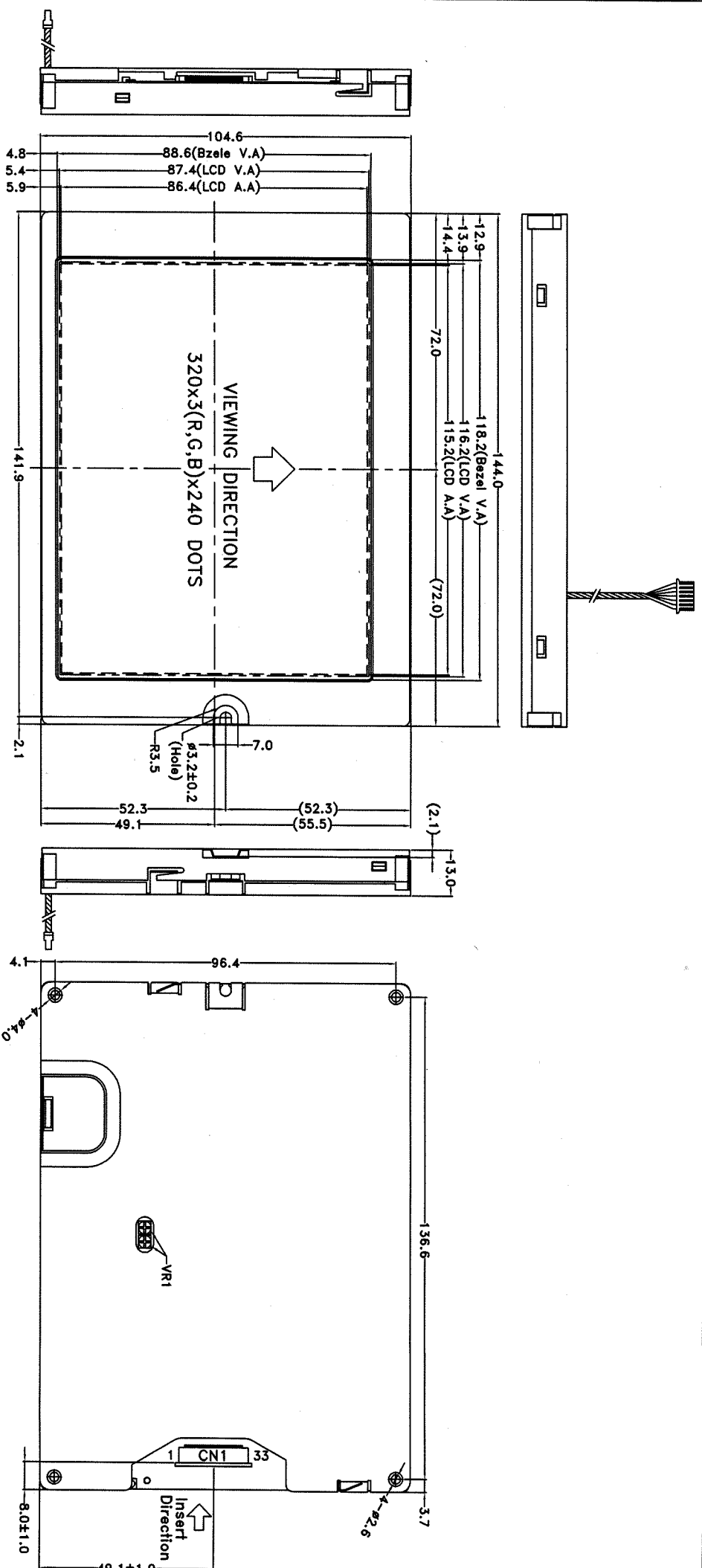

CN2 Pin Assign

Pin	Description	Cable Color
1	Anode1	Black
2	Anode2	Black
3	Anode3	Red
4	Cathode1	White
5	Cathode2	Black
6	Cathode3	Red

- Note:
1. The tolerance unless classified $\pm 0.5\text{mm}$
 2. LCD type: a-si TFT
 3. LCD mode: Positive / Transmissive
 4. View direction: 0° clock
 5. $T_{st} = -20^{\circ}\text{C} \sim 70^{\circ}\text{C}$, $T_v = -30^{\circ}\text{C} \sim 80^{\circ}\text{C}$
 6. CN1: 08-6210-033-340-800+(ELCO)
 - CN2: SHLP-06V-S-8(JST)

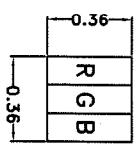

Detail Dots
Scale: 50/1

REV	Modify spec	SEP/04/07	圖面名稱	SCALE:1/1.6	UNIT:mm	PAGE:1/1	APPROVED	CHECKER	DRAWN
	DESCRIPTION	DATE	圖面編號	PH-07015-004	ED1	A	久正光電股份有限公司 POWER TIP TECHNOLOGY CORPORATION	研發 黃秋源 研發 石建莊 研發 郭政球	

2-060-01-01