

Tentative Specification

G141I1-L01

Version June 2008

Note: This specification is subject to change without prior notice

- CONTENTS -

REVISION HISTORY	-----	3
1. GENERAL DESCRIPTION	-----	4
1.1 OVERVIEW		
1.2 FEATURES		
1.3 APPLICATION		
1.4 GENERAL SPECIFICATIONS		
1.5 MECHANICAL SPECIFICATIONS		
2. ABSOLUTE MAXIMUM RATINGS	-----	6
2.1 ABSOLUTE RATINGS OF ENVIRONMENT		
2.2 ELECTRICAL ABSOLUTE RATINGS		
2.2.1 TFT LCD MODULE		
2.2.2 BACKLIGHT UNIT		
3. ELECTRICAL CHARACTERISTICS	-----	7
3.1 TFT LCD MODULE		
3.2 BACKLIGHT UNIT		
4. BLOCK DIAGRAM	-----	11
4.1 TFT LCD MODULE		
4.2 BACKLIGHT UNIT		
5. INPUT TERMINAL PIN ASSIGNMENT	-----	12
5.1 TFT LCD MODULE		
5.2 BACKLIGHT UNIT		
5.3 TIMING DIAGRAM OF LVDS INPUT SIGNAL		
5.4 COLOR DATA INPUT ASSIGNMENT		
6. INTERFACE TIMING	-----	15
6.1 INPUT SIGNAL TIMING SPECIFICATIONS		
6.2 POWER ON/OFF SEQUENCE		
7. OPTICAL CHARACTERISTICS	-----	17
7.1 TEST CONDITIONS		
7.2 OPTICAL SPECIFICATIONS		
8. PRECAUTIONS	-----	21
8.1 ASSEMBLY HANDLING PRECAUTIONS		
8.2 SAFETY PRECAUTIONS		
9. PACKING	-----	22
9.1 CARTON		
9.2 PALLET		
10. DEFINITION OF LABELS	-----	24
10.1 CMO MODULE LABEL		
11. MECHANICAL CHARACTERISTICS	-----	25

REVISION HISTORY

Version	Date	Section	Description
Ver 0.0	Jun. 18, 2008	All	G14111-L01 Tentative Spec. was first issued.

1. GENERAL DESCRIPTION

1.1 OVERVIEW

G14111 - L01 is a 14.1" TFT Liquid Crystal Display module and 20 pins LVDS interface. This module supports 1280 x 800 WXGA mode and can display 262,144 colors. The inverter module for Backlight is not built in.

1.2 FEATURES

- WXGA (1280 x 800 pixels) resolution
- DE only mode
- LVDS interface
- High brightness
- High color saturation
- High contrast ratio
- Wide operating temperature range (-30 to 80)
- Lamp replaceable
- Sunlight readable
- Reversible scan function
- RoHS compliance

1.3 APPLICATION

- TFT LCD Panel
- Factory Application

1.4 GENERAL SPECIFICATIONS

Item	Specification	Unit	Note
Active Area	303.4 x 189.6	mm	(1)
Bezel Opening Area	306.4 x 192.6	mm	
Driver Element	a-si TFT active matrix	-	-
Pixel Number	1280xR.G.Bx800	pixel	-
Pixel Pitch	0.237(H) x 0.237(V)	mm	-
Pixel Arrangement	RGB vertical stripe	-	-
Display Colors	262,144	color	-
Transmissive Mode	Normally white	-	-
Surface Treatment	Glare,3H,LR	-	-

1.5 MECHANICAL SPECIFICATIONS

Item		Min.	Typ.	Max.	Unit	Note
Module Size	Horizontal(H)	325.5	326	326.5	mm	(1)
	Vertical(V)	216	216.5	217	mm	
	Depth(D)	15.5	16	16.5	mm	
Weight				1200	g	
I/F connector mounting position		The mounting inclination of the connector makes the screen center within $\pm 0.5\text{mm}$ as the horizontal.				(2)

Note (1) Please refer to the attached drawings for more information of front and back outline dimensions.

Note (2) Connector mounting position

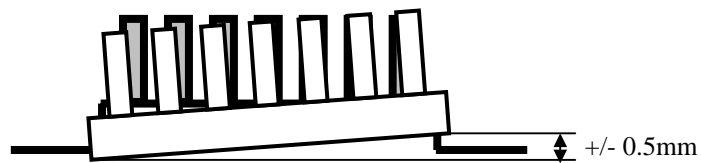

2. ABSOLUTE MAXIMUM RATINGS

2.1 ABSOLUTE RATINGS OF ENVIRONMENT

Test Item	Test Condition	Note
High Temperature Storage Test	90°C, 240hours	(1) (3)
Low Temperature Storage Test	-40°C, 240hours	
Thermal Shock Storage Test	-40°C, 0.5hour ~ 85°C, 0.5hour, 100 cycles	
High Temperature Operation Test	80°C, 240hours	
Low Temperature Operation Test	-30°C, 240hours	
High Temperature & High Humidity Operation Test	60°C 90%RH, 240hours	
ESD Test (Operation)	150pF, 330 Ω, 1sec/cycle Condition 1 : panel contact, ±8KV Condition 2 : panel non-contact ±15KV	(1)
Shock (Non-Operating)	50G, 11ms, half sine wave, 1 time for ± X, ± Y, ± Z direction	(1)(2)
Vibration (Non-Operating)	1.5G, 10 ~ 300 Hz sine wave, 10min/cycle, 3 cycles each X, Y, Z direction	(1)(2)

Note (1) No display malfunctions.

Note (2) At testing Vibration and Shock, the fixture in holding the module has to be hard and rigid enough so that the module would not be twisted or bent by the fixture.

Note (3) Temperature of panel display surface area should be 85 °C Max.

Note (4) In the standard conditions, there is no function failure issue occurred. All the cosmetic specification is judged before the reliability test

2.2 ELECTRICAL ABSOLUTE RATINGS

2.2.1 TFT LCD MODULE

Item	Symbol	Value		Unit	Note
		Min.	Max.		
Power Supply Voltage	V _{CC}	-0.3	+4.0	V	(1)
Logic Input Voltage	V _{IN}	-0.3	V _{CC} +0.3	V	

2.2.2 BACKLIGHT UNIT

Item	Symbol	Value		Unit	Note
		Min.	Max.		
Lamp Voltage	V _L		2.5	V _{RMS}	(1), (2), I _L = 7.0 mA
Lamp Current	I _L		7.5	mA _{RMS}	
Lamp Frequency	F _L	40	80	KHZ	(1), (2)

Note (1) Permanent damage to the device may occur if maximum values are exceeded. Function operation should be restricted to the conditions described under Normal Operating Conditions.

Note (2) Specified values are for lamp (Refer to 3.2 for further information).

3. ELECTRICAL CHARACTERISTICS

3.1 TFT LCD MODULE

Parameter	Symbol	Value			Unit	Note
		Min.	Typ.	Max.		
Power Supply Voltage	V _{CC}	3.0	3.3	3.6	V	-
Permissible Ripple Voltage	V _{RP}		50		mV	-
Rush Current	I _{RUSH}			1.5	A	(2)
Initial Stage Current	I _{IS}			1.0	A	(2)
Power Supply Current	I _{CC}		(340)	(380)	mA	(3)a
			(440)	(480)	mA	(3)b
LVDS Differential Input High Threshold	V _{TH(LVDS)}			+100	mV	(5), V _{CM} =1.2V
LVDS Differential Input Low Threshold	V _{TL(LVDS)}	-100			mV	(5) V _{CM} =1.2V
LVDS Common Mode Voltage	V _{CM}	1.125		1.375	V	(5)
LVDS Differential Input Voltage	V _{ID}	100		600	mV	(5)
Terminating Resistor	R _T		100		Ohm	
Power per EBL WG	P _{EBL}	-	TBD	-	W	(4)

Note (1) The ambient temperature is Ta = 25 ± 2 °C.

Note (2) I_{RUSH}: the maximum current when V_{CC} is rising

I_{IS}: the maximum current of the first 100ms after power-on

Measurement Conditions: Shown as the following figure. Test pattern: black.

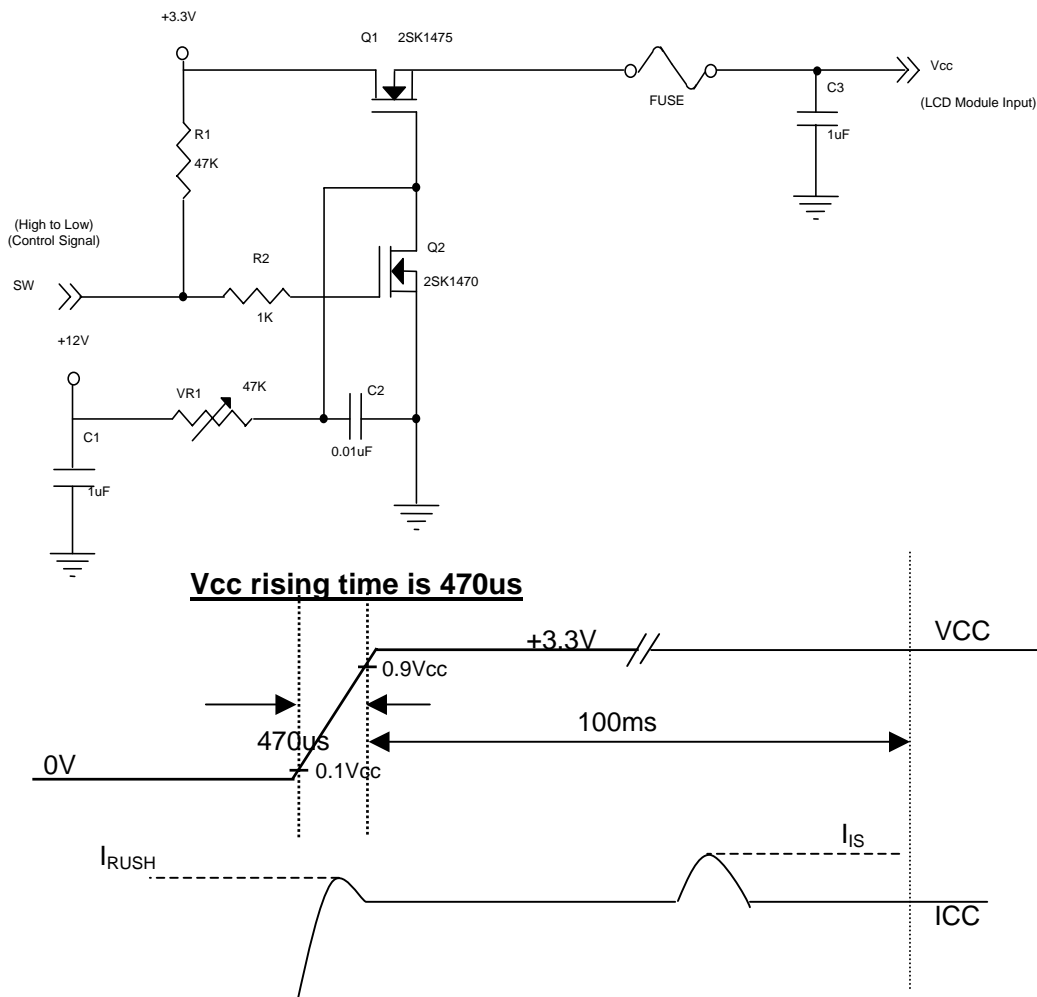

Note (3) The specified power supply current is under the conditions at $V_{CC} = 3.3\text{ V}$, $T_a = 25 \pm 2\text{ }^\circ\text{C}$, $f_v = 60\text{ Hz}$, whereas a power dissipation check pattern below is displayed.

a. White Pattern

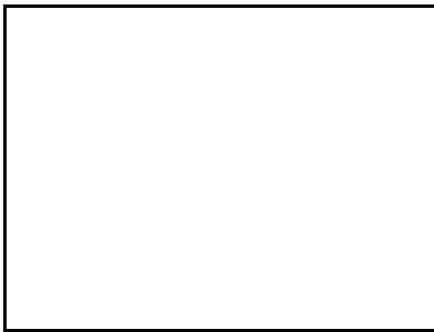

Active Area

b. Black Pattern

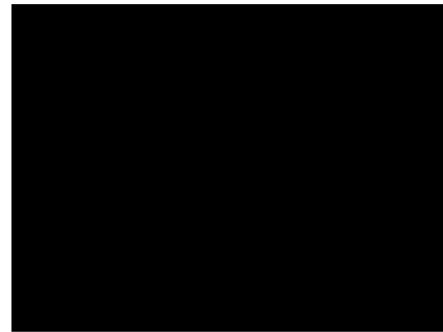

Active Area

Note (4) The specified power are the sum of LCD panel electronics input power and the inverter input power. Test conditions are as follows.

- (a) $V_{CC} = 3.3\text{ V}$, $T_a = 25 \pm 2\text{ }^\circ\text{C}$, $f_v = 60\text{ Hz}$,
- (b) The pattern used is a black and white 32 x 36 checkerboard, slide #100 from the VESA file "Flat Panel Display Monitor Setup Patterns", FPDMSU.ppt.
- (c) Luminance: 60 nits.
- (d) The inverter used is provided from "Darfon VK16165.101" Please contact them for detail information. CMO doesn't provide the inverter in this product.

Note (5) The parameters of LVDS signals are defined as the following figures.

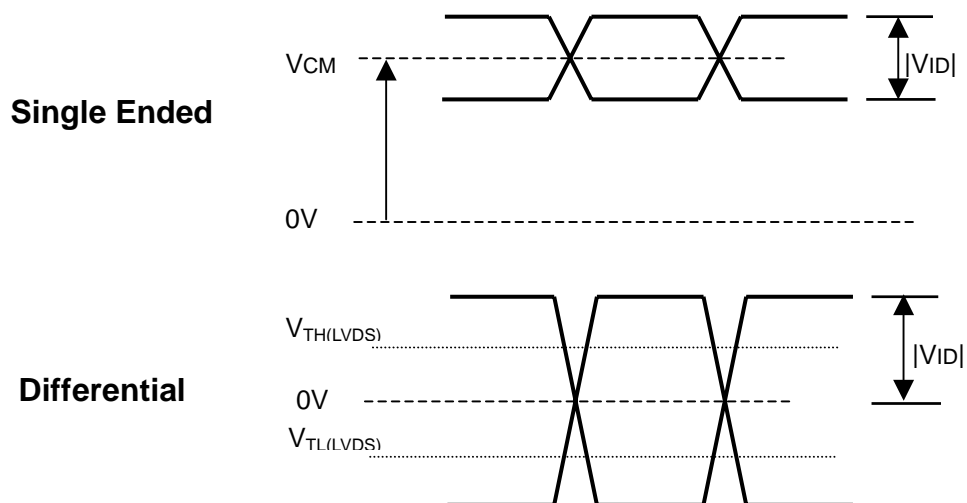

3.2 BACKLIGHT UNIT

Ta = 25 ± 2 °C

Parameter	Symbol	Value			Unit	Note
		Min.	Typ.	Max.		
Lamp Input Voltage	V _L	--	560		V _{RMS}	I _L = 7.0 mA
Lamp Current	I _L		7.0		mA _{RMS}	(1)
Lamp Turn On Voltage	V _s			1150(25 °C)	V _{RMS}	(2)
				1370(0 °C)	V _{RMS}	(2)
Operating Frequency	F _L	40			KHz	(3)
Lamp Life Time	L _{BL}		50000		Hrs	(5)
Power Consumption	P _L		15.68		W	(4), I _L = 7.0 mA

Note (1) Lamp current is measured by utilizing a high frequency current meter as shown below:

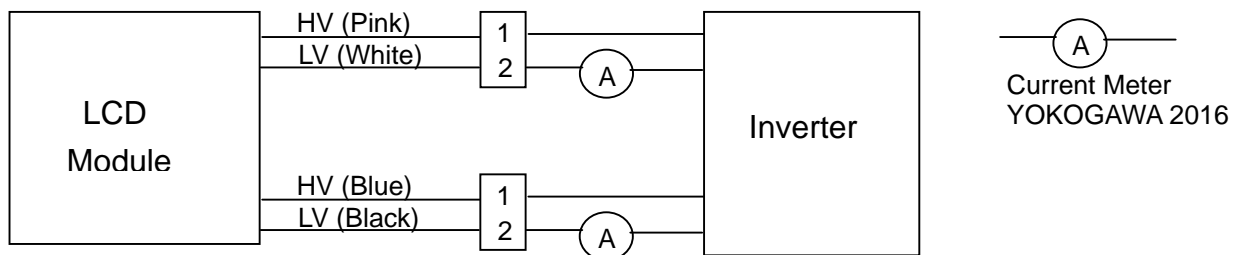

Note (2) The voltage that must be larger than V_s should be applied to the lamp for more than 1 second after startup. Otherwise, the lamp may not be turned on normally.

Note (3) The lamp frequency may produce interference with horizontal synchronous frequency from the display, and this may cause line flow on the display. In order to avoid interference, the lamp frequency should be detached from the horizontal synchronous frequency and its harmonics as far as possible.

Note (4) $P_L = I_L \times V_L \times 4CCLFs$

Note (5) The lifetime of lamp can be defined as the time in which it continues to operate under the condition Ta = 25 ± 2 °C and I_L = 6.5 mA_{RMS} until one of the following events occurs:

- (a) When the brightness becomes or lower than 50% of its original value.
- (b) When the effective ignition length becomes ≤ 80% of its original value. (The effective ignition length is a scope that luminance is over 70% of that at the center point.)

Note (6) The waveform of the voltage output of inverter must be area-symmetric and the design of the inverter must have specifications for the modularized lamp. The performance of the Backlight, such as lifetime or brightness, is greatly influenced by the characteristics of the DC-AC inverter for the lamp. All the parameters of an inverter should be carefully designed to avoid producing too much current leakage from high voltage output of the inverter. When designing or ordering the inverter please make sure that a poor lighting caused by the mismatch of the Backlight and the inverter (miss-lighting, flicker, etc.) never occurs. If the above situation is confirmed, the module should be operated in the same manners when it is installed in your instrument.

The output of the inverter must have symmetrical (negative and positive) voltage waveform and

symmetrical current waveform.(Unsymmetrical ratio is less than 10%) Please do not use the inverter which has unsymmetrical voltage and unsymmetrical current and spike wave. Lamp frequency may produce interface with horizontal synchronous frequency and as a result this may cause beat on the display. Therefore lamp frequency shall be as away possible from the horizontal synchronous frequency and from its harmonics in order to prevent interference.

Requirements for a system inverter design, which is intended to have a better display performance, a better power efficiency and a more reliable lamp. It shall help increase the lamp lifetime and reduce its leakage current.

- The asymmetry rate of the inverter waveform should be 10% below.
- The distortion rate of the waveform should be within $2 \pm 10\%$.
- The ideal sine wave form shall be symmetric in positive and negative polarities.

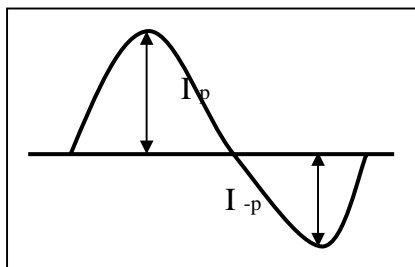

* Asymmetry rate:

$$| I_p - I_{-p} | / I_{rms} * 100\%$$

* Distortion rate

$$I_p \text{ (or } I_{-p}) / I_{rms}$$

4. BLOCK DIAGRAM

4.1 TFT LCD MODULE

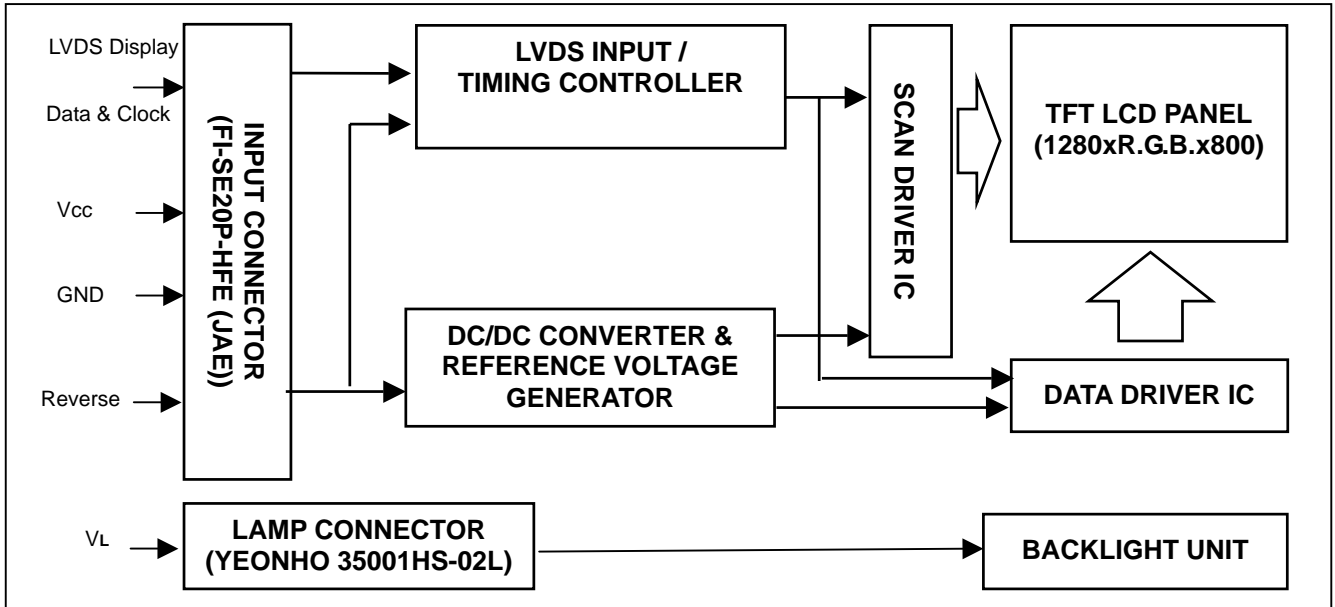

4.2 BACKLIGHT UNIT

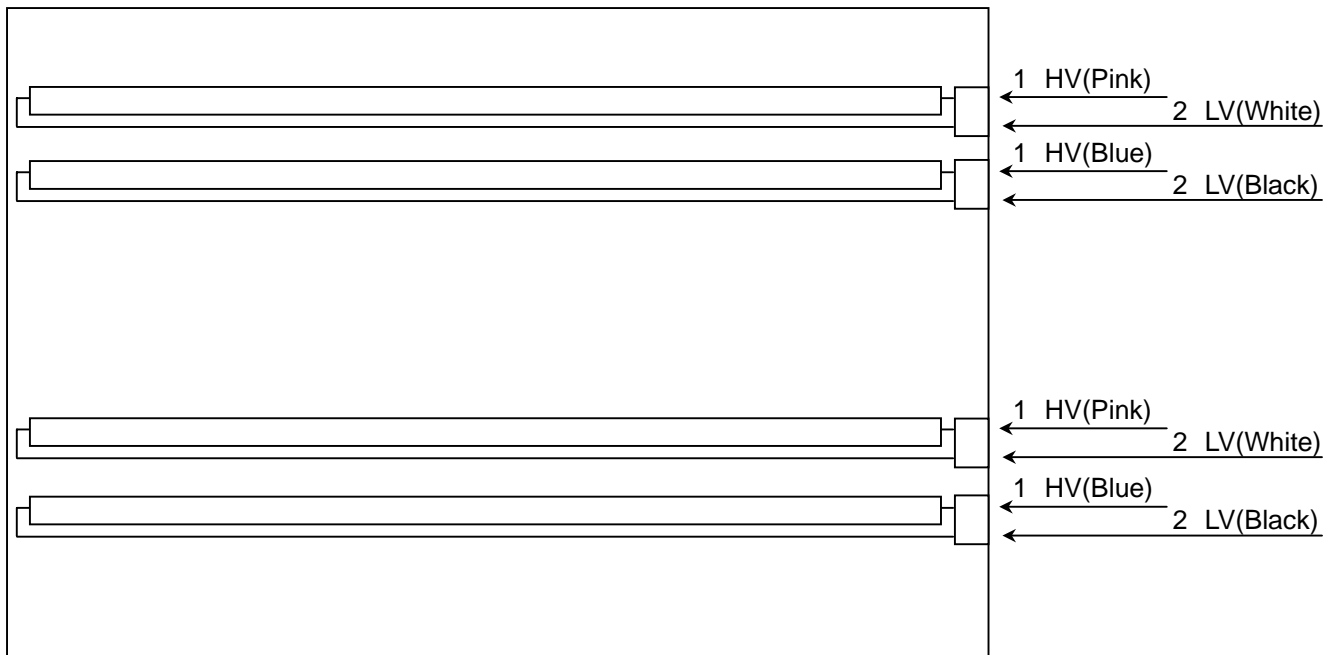

Note : On the same side, the same polarity lamp voltage design for lamps is recommended

5. INPUT TERMINAL PIN ASSIGNMENT

5.1 TFT LCD MODULE

Pin	Symbol	Description	Polarity	Remark
1	VCCS	Power Supply +3.3 V (typical)		
2	VCCS	Power Supply +3.3 V (typical)		
3	GND	Ground		
4	GND	Ground		
5	RX0-	LVDS Differential Data Input	Negative	R0~R5,G0
6	RX0+	LVDS Differential Data Input	Positive	
7	GND	Ground		
8	RX1-	LVDS Differential Data Input	Negative	G1~G5, B0, B1
9	RX1+	LVDS Differential Data Input	Positive	
10	GND	Ground		
11	RX2-	LVDS Differential Data Input	Negative	B2~B5, DE, Hsync, Vsync
12	RX2+	LVDS Differential Data Input	Positive	
13	GND	Ground		
14	CLK-	LVDS Clock Data Input	Negative	LVDS Level Clock
15	CLK+	LVDS Clock Data Input	Positive	
16	GND	Ground		
17	NC	Non-Connection		
18	NC	Non-Connection		
19	Reverse	+3.3VReverse, GND/NC No Reverse		Refer to 6.2 POWER ON/OFF SEQUENCE Note(5)
20	NC	Non-Connection		

Note (1) Connector Part No.: FI-SE20P-HFE(JAE) or equivalent

Note (2) User's connector Part No: FI-SE20ME (JAE) or equivalent

Note (3) The first pixel is odd as shown in the following figure.

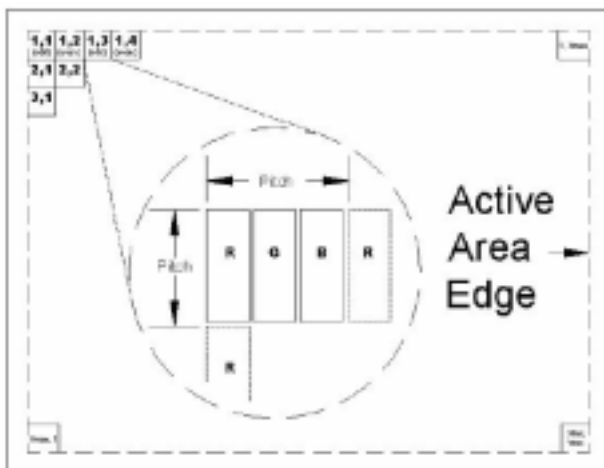

Note (4) Scanning direction:

The following figures are seen from a front view and the arrow shows the direction of scan.

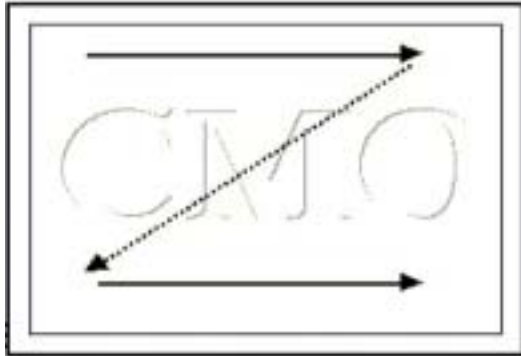

Reverse = GND/NC : normal display (default)

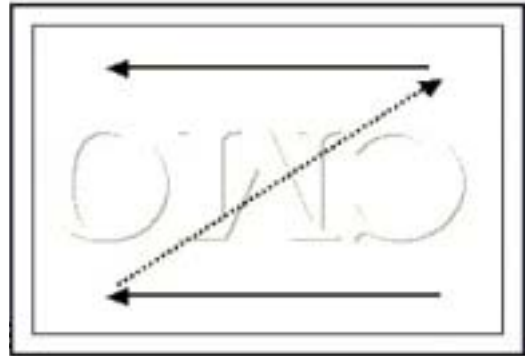

Reverse = High : display with 180 degree rotation

5.2 BACKLIGHT UNIT

Pin	Symbol	Description	Color
1	HV	High Voltage	Pink
2	LV	Ground	White

Note (1) Connector Part No.: YEONHO 35001HS-02L or equivalent

Note (2) User's connector Part No.: YEONHO 35001 WR-02L or equivalent

5.3 TIMING DIAGRAM OF LVDS INPUT SIGNAL

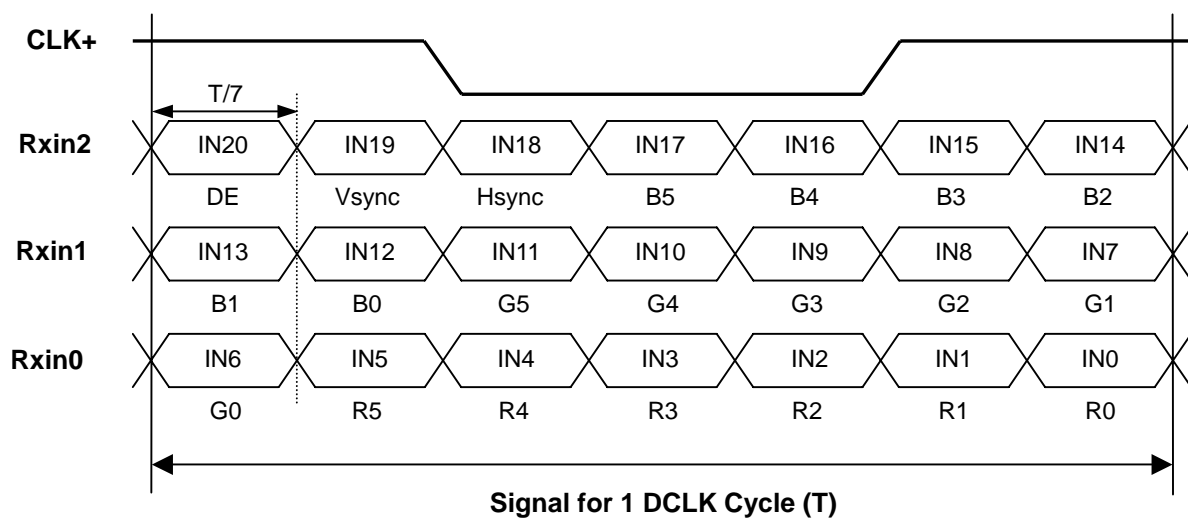

5.4 COLOR DATA INPUT ASSIGNMENT

The brightness of each primary color (red, green and blue) is based on the 6-bit gray scale data input for the color. The higher the binary input, the brighter the color. The table below provides the assignment of color versus data input.

Color		Data Signal																	
		Red						Green						Blue					
		R5	R4	R3	R2	R1	R0	G5	G4	G3	G2	G1	G0	B5	B4	B3	B2	B1	B0
Basic Colors	Black	0	0	0	0	0	0	0	0	0	0	0	0	0	0	0	0	0	0
	Red	1	1	1	1	1	1	0	0	0	0	0	0	0	0	0	0	0	0
	Green	0	0	0	0	0	0	1	1	1	1	1	1	0	0	0	0	0	0
	Blue	0	0	0	0	0	0	0	0	0	0	0	0	1	1	1	1	1	1
	Cyan	0	0	0	0	0	0	1	1	1	1	1	1	1	1	1	1	1	1
	Magenta	1	1	1	1	1	1	0	0	0	0	0	0	1	1	1	1	1	1
	Yellow	1	1	1	1	1	1	1	1	1	1	1	1	0	0	0	0	0	0
	White	1	1	1	1	1	1	1	1	1	1	1	1	1	1	1	1	1	1
Gray Scale Of Red	Red(0)/Dark	0	0	0	0	0	0	0	0	0	0	0	0	0	0	0	0	0	0
	Red(1)	0	0	0	0	0	1	0	0	0	0	0	0	0	0	0	0	0	0
	Red(2)	0	0	0	0	1	0	0	0	0	0	0	0	0	0	0	0	0	0
	:	:	:	:	:	:	:	:	:	:	:	:	:	:	:	:	:	:	:
	:	:	:	:	:	:	:	:	:	:	:	:	:	:	:	:	:	:	:
	Red(61)	1	1	1	1	0	1	0	0	0	0	0	0	0	0	0	0	0	0
	Red(62)	1	1	1	1	1	0	0	0	0	0	0	0	0	0	0	0	0	0
	Red(63)	1	1	1	1	1	1	0	0	0	0	0	0	0	0	0	0	0	0
Gray Scale Of Green	Green(0)/Dark	0	0	0	0	0	0	0	0	0	0	0	0	0	0	0	0	0	0
	Green(1)	0	0	0	0	0	0	0	0	0	0	1	0	0	0	0	0	0	0
	Green(2)	0	0	0	0	0	0	0	0	0	1	0	0	0	0	0	0	0	0
	:	:	:	:	:	:	:	:	:	:	:	:	:	:	:	:	:	:	:
	:	:	:	:	:	:	:	:	:	:	:	:	:	:	:	:	:	:	:
	Green(61)	0	0	0	0	0	0	1	1	1	1	0	1	0	0	0	0	0	0
	Green(62)	0	0	0	0	0	0	1	1	1	1	1	0	0	0	0	0	0	0
	Green(63)	0	0	0	0	0	0	1	1	1	1	1	1	0	0	0	0	0	0
Gray Scale Of Blue	Blue(0)/Dark	0	0	0	0	0	0	0	0	0	0	0	0	0	0	0	0	0	0
	Blue(1)	0	0	0	0	0	0	0	0	0	0	0	0	0	0	0	0	0	1
	Blue(2)	0	0	0	0	0	0	0	0	0	0	0	0	0	0	0	0	1	0
	:	:	:	:	:	:	:	:	:	:	:	:	:	:	:	:	:	:	:
	:	:	:	:	:	:	:	:	:	:	:	:	:	:	:	:	:	:	:
	Blue(61)	0	0	0	0	0	0	0	0	0	0	0	0	1	1	1	1	0	1
	Blue(62)	0	0	0	0	0	0	0	0	0	0	0	0	1	1	1	1	1	0
	Blue(63)	0	0	0	0	0	0	0	0	0	0	0	0	1	1	1	1	1	1

Note (1) 0: Low Level Voltage, 1: High Level Voltage

6. INTERFACE TIMING

6.1 INPUT SIGNAL TIMING SPECIFICATIONS

The specifications of input signal timing are as the following table and timing diagram.

Signal	Item	Symbol	Min.	Typ.	Max.	Unit	Note
DCLK	Frequency	1/Tc	(63.9)	71	(74.5)	MHz	-
DE	Vertical Total Time	TV	802	823	1030	TH	-
	Vertical Active Display Period	TVD	800	800	800	TH	-
	Vertical Active Blanking Period	TVB	TV-TVD	23	TV-TVD	TH	-
	Horizontal Total Time	TH	1360	1440	1600	Tc	-
	Horizontal Active Display Period	THD	1280	1280	1280	Tc	-
	Horizontal Active Blanking Period	THB	TH-THD	160	TH-THD	Tc	-

Note (1) Because this module is operated by DE only mode, Hsync and Vsync are ignored.

INPUT SIGNAL TIMING DIAGRAM

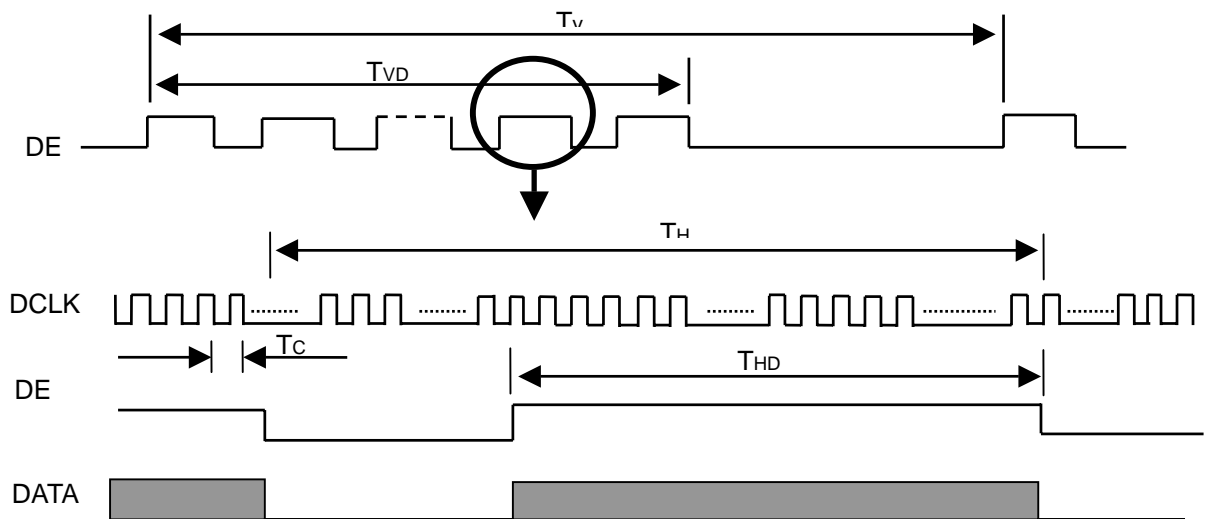

6.2 POWER ON/OFF SEQUENCE

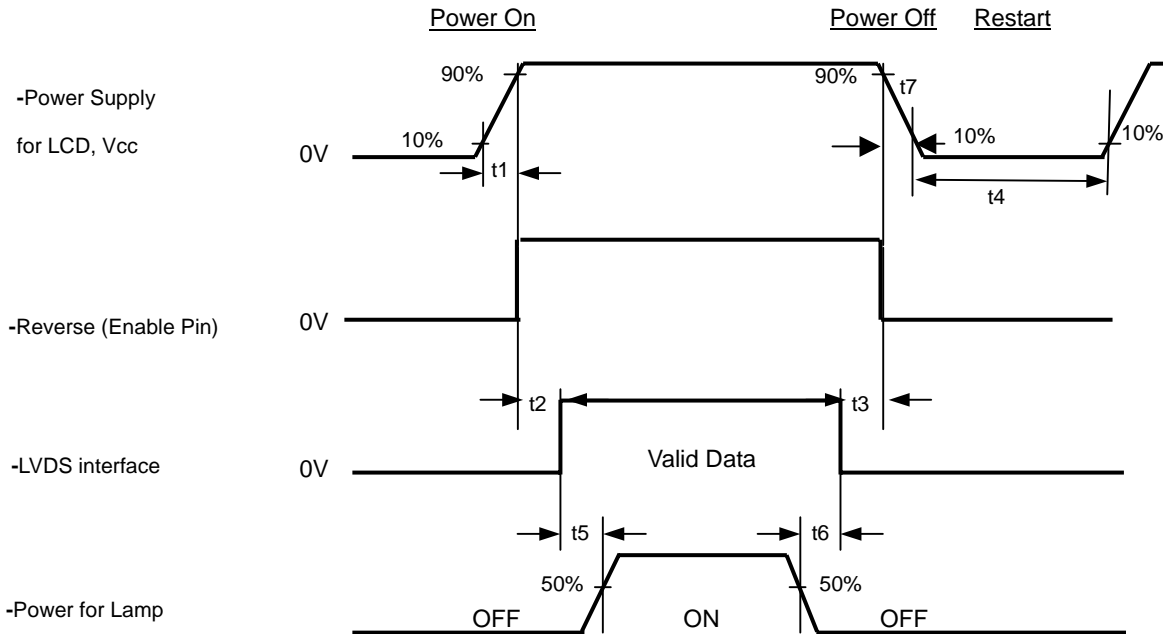

Timing Specifications:

0.5	t1	10 ms
0	t2	50 ms
0	t3	50 ms
	t4	500 ms
	t5	200 ms
	t6	200 ms

Note (1) Please follow the power on/off sequence described above. Otherwise, the LCD module might be damaged.

Note (2) Please avoid floating state of interface signal at invalid period. When the interface signal is invalid, be sure to pull down the power supply of LCD Vcc to 0 V.

Note (3) The Backlight inverter power must be turned on after the power supply for the logic and the interface signal is valid. The Backlight inverter power must be turned off before the power supply for the logic and the interface signal is invalid.

Note (4) Sometimes some slight noise shows when LCD is turned off (even backlight is already off). To avoid this phenomenon, we suggest that the Vcc falling time is better to follow 5 t7 300 ms.

Note (5) Reverse Pin not change signal when Panel Normal Displaying.

7. OPTICAL CHARACTERISTICS

7.1 TEST CONDITIONS

Item	Symbol	Value	Unit
Ambient Temperature	T _a	25±2	°C
Ambient Humidity	H _a	50±10	%RH
Supply Voltage	V _{CC}	3.3	V
Input Signal	According to typical value in "3. ELECTRICAL CHARACTERISTICS"		
Inverter Current	I _L	6.5	mA
Inverter Driving Frequency	F _L	61	KHz
Inverter	Darfon VK13165.101		

The relative measurement methods of optical characteristics are shown in 7.2. The following items should be measured under the test conditions described in 7.1 and stable environment shown in Note (6).

7.2 OPTICAL SPECIFICATIONS

Item	Symbol	Condition	Min.	Typ.	Max.	Unit	Note	
Contrast Ratio	CR	$\theta_x=0^\circ, \theta_y=0^\circ$ Viewing Normal Angle	500	700		-	(2), (5)	
Response Time	T _R				5	10	ms	(3)
	T _F				11	16	ms	
Center Luminance of White	L _{CEN}			500	600		cd/m ²	(4), (5)
White Variation	δW				1.25	1.4	-	(5), (6)
Color Chromaticity	Red		R _x	Typ- 0.03	0.618	Typ+ 0.03	-	(1)
			R _y		0.343		-	
	Green		G _x		0.306		-	
			G _y		0.587		-	
	Blue		B _x		0.145		-	
		B _y	0.103		-			
	White	W _x	0.313		-			
		W _y	0.329		-			
Viewing Angle	Horizontal	θ _{x+}	70	80		Deg.		
		θ _{x-}	70	80				
	Vertical	θ _{y+}	60	70				
		θ _{y-}	60	70				

Note (1) Definition of Viewing Angle (θ_x, θ_y):

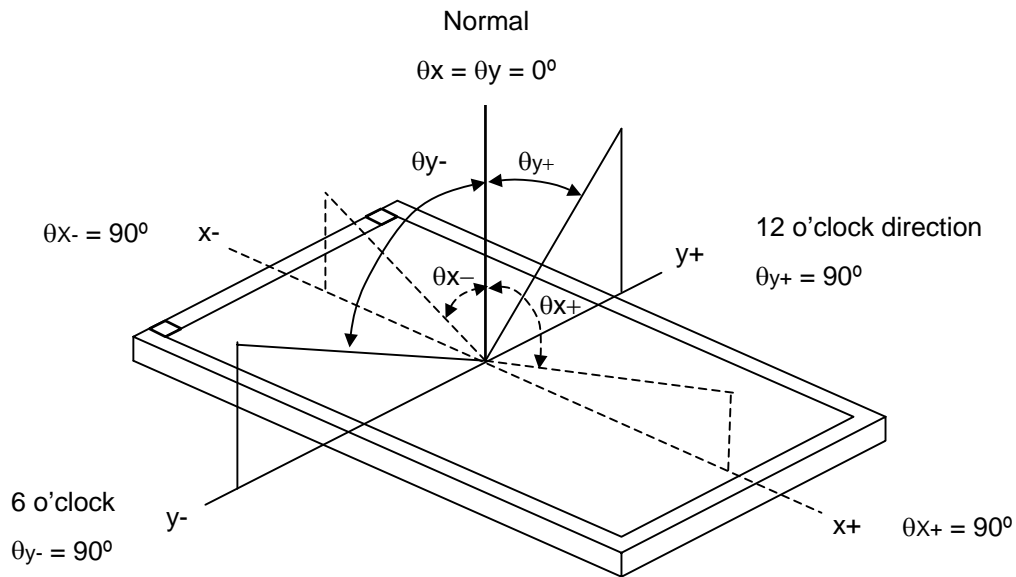

Note (2) Definition of Contrast Ratio (CR):

The contrast ratio can be calculated by the following expression.

$$\text{Contrast Ratio (CR)} = L_{63} / L_0$$

L63: Luminance of gray level 63

L 0: Luminance of gray level 0

$$\text{CR} = \text{CR} (5)$$

CR (X) is corresponding to the Contrast Ratio of the point X at Figure in Note (6).

Note (3) Definition of Response Time (T_R, T_F) and measurement method:

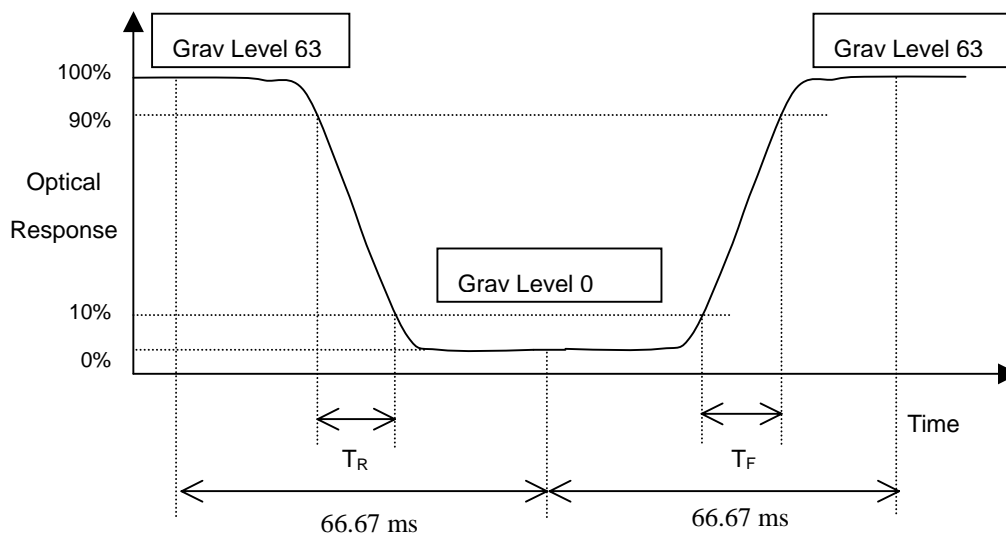

Note (4) Definition of Average Luminance of White (L_{CEN}):

Measure the luminance of gray level 63 at 5 points

$$L_{CEN} = L(5)$$

$L(x)$ is corresponding to the luminance of the point X at Figure in Note (6).

Note (5) Measurement Setup:

The LCD module should be stabilized at given temperature for 20 minutes to avoid abrupt temperature change during measuring. In order to stabilize the luminance, the measurement should be executed after lighting Backlight for 20 minutes in a windless room.

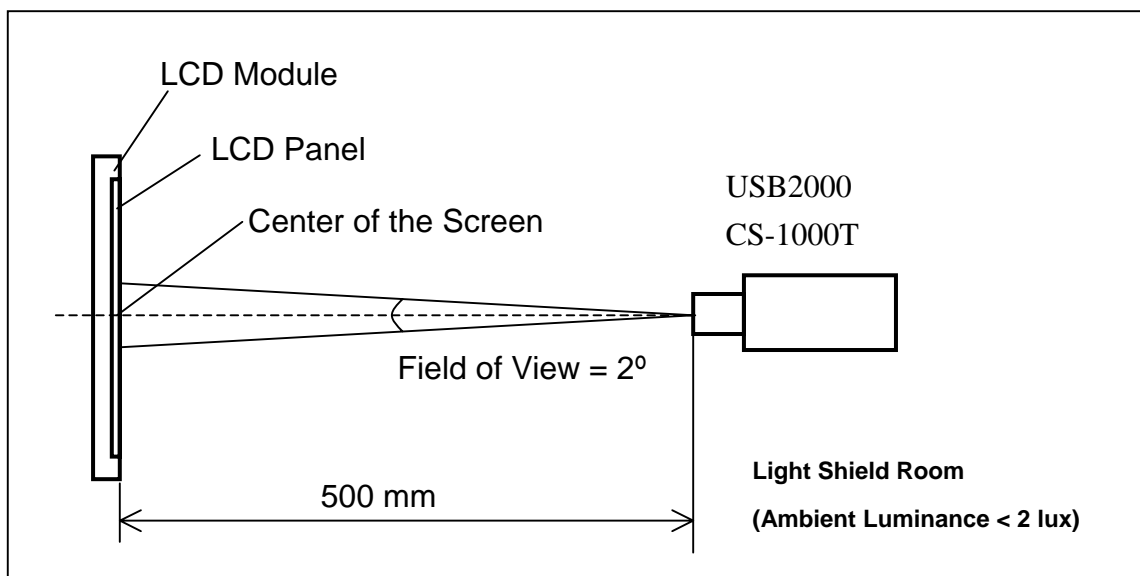

Note (6) Definition of White Variation (δW):

Measure the luminance of gray level 63 at 5 points

$$\delta W = \text{Maximum} [L(1), L(2), L(3), L(4), L(5)] / \text{Minimum} [L(1), L(2), L(3), L(4), L(5)]$$

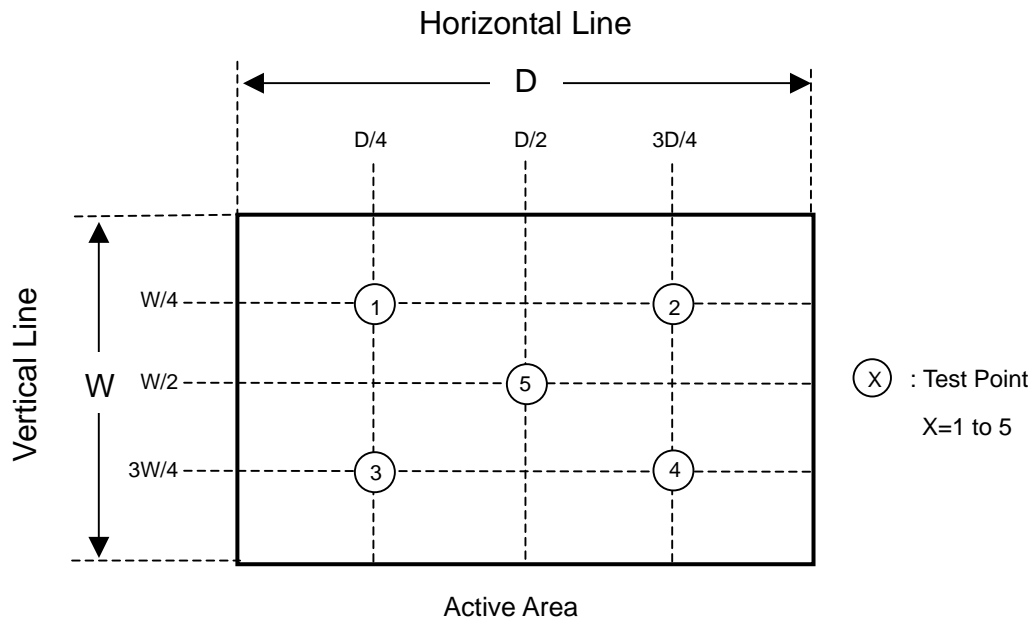

8. PRECAUTIONS

8.1 ASSEMBLY AND HANDLING PRECAUTIONS

- (1) Do not apply rough force such as bending or twisting to the module during assembly.
- (2) To assemble or install module into user's system can be only in clean working areas. The dust and oil may cause electrical short or worsen the polarizer.
- (3) It's not permitted to have pressure or impulse on the module because the LCD panel and Backlight will be damaged.
- (4) Always follow the correct power sequence when LCD module is connecting and operating. This can prevent damage to the CMOS LSI chips during latch-up.
- (5) Do not pull the I/F connector in or out while the module is operating.
- (6) Do not disassemble the module.
- (7) Use a soft dry cloth without chemicals for cleaning, because the surface of polarizer is very soft and easily scratched.
- (8) It is dangerous that moisture come into or contacted the LCD module, because moisture may damage LCD module when it is operating.
- (9) High temperature or humidity may reduce the performance of module. Please store LCD module within the specified storage conditions.
- (10) When ambient temperature is lower than 10°C may reduce the display quality. For example, the response time will become slowly, and the starting voltage of CCFL will be higher than room temperature.

8.2 SAFETY PRECAUTIONS

- (1) The startup voltage of Backlight is approximately 1000 Volts. It may cause electrical shock while assembling with inverter. Do not disassemble the module or insert anything into the Backlight unit.
- (2) If the liquid crystal material leaks from the panel, it should be kept away from the eyes or mouth. In case of contact with hands, skin or clothes, it has to be washed away thoroughly with soap.
- (3) After the module's end of life, it is not harmful in case of normal operation and storage.

9. PACKAGING
9.1 CARTON

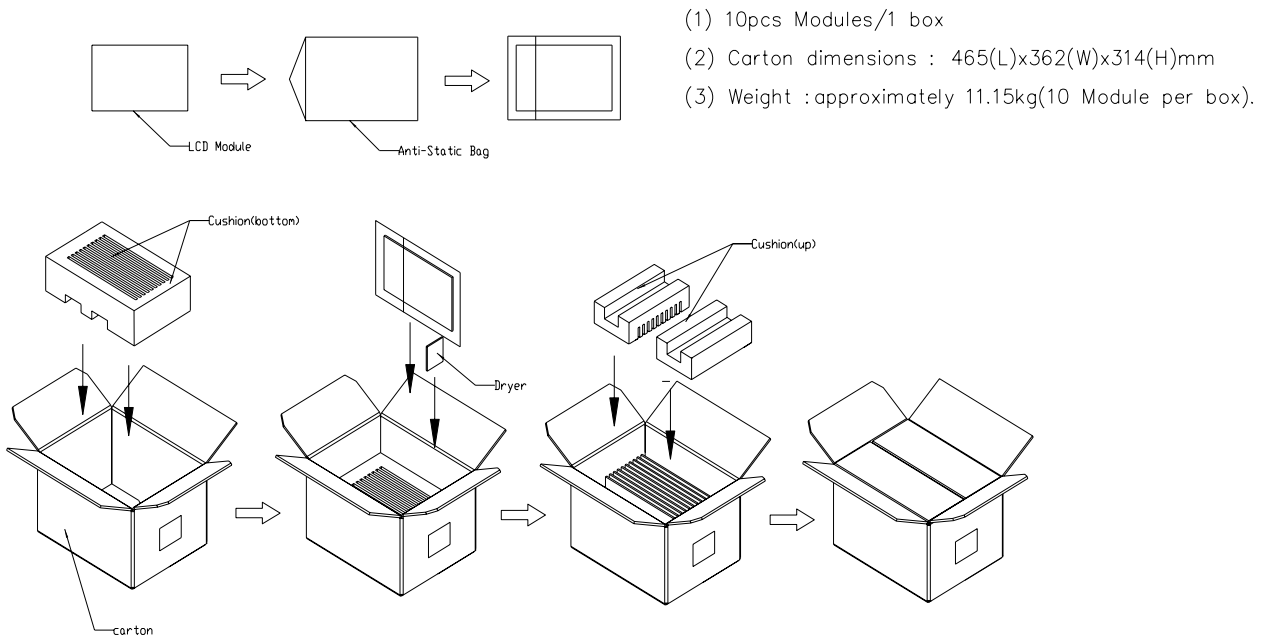

Figure. 8-1 Packing method

9.2 PALLET

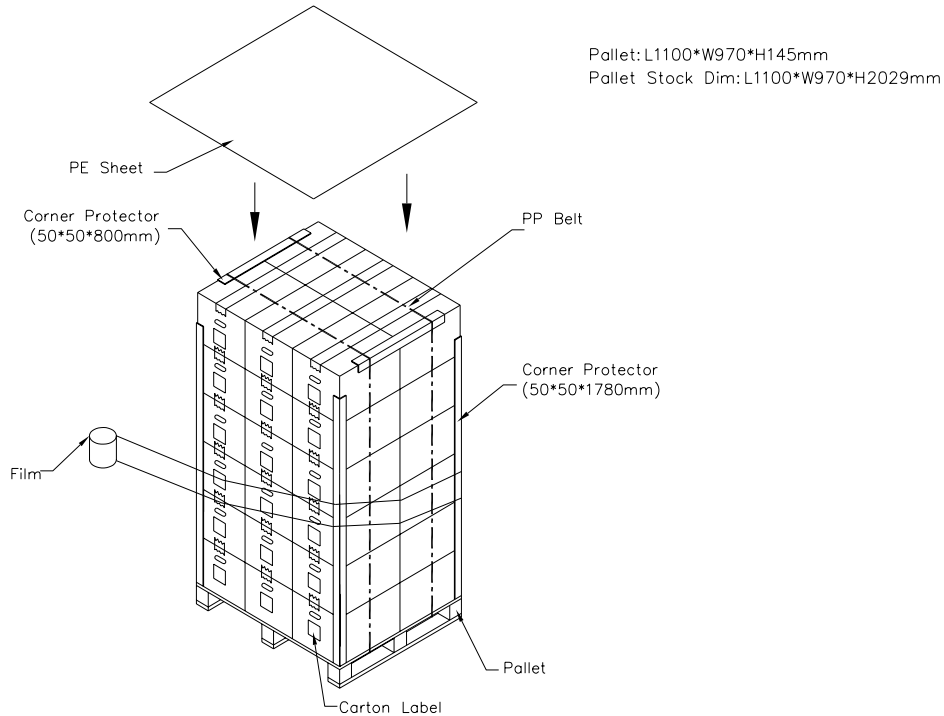

Figure. 9-2 Packing method

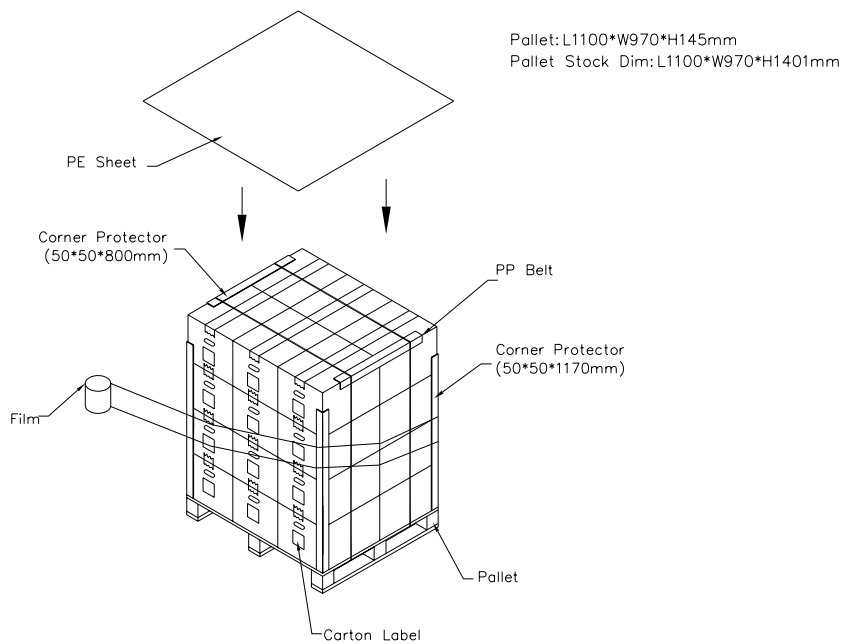
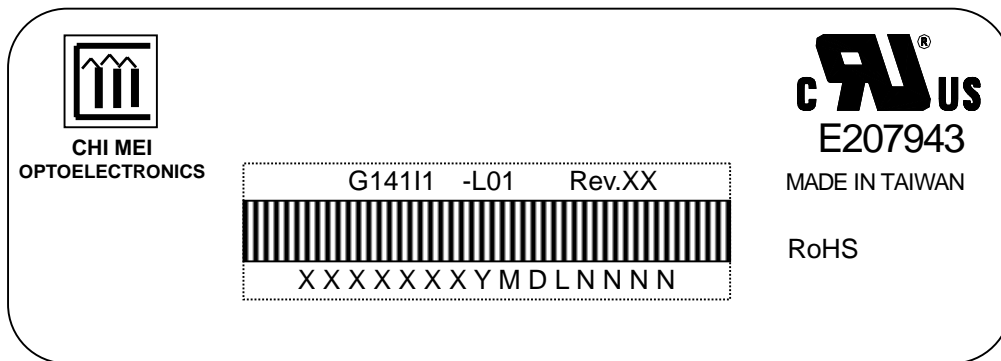

Figure. 9-3 Packing method

10. DEFINITION OF LABELS

10.1 CMO MODULE LABEL

The barcode nameplate is pasted on each module as illustration, and its definitions are as following explanation.



- (a) Model Name: G14111 - L01
- (b) Revision: Rev. XX, for example: A1, ...C1, C2 ...etc.
- (c) Serial ID: XXXXXXXXYMDXNNNN

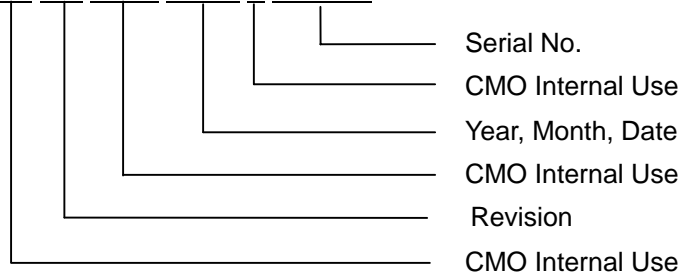

Serial ID includes the information as below:

- (a) Manufactured Date: Year: 1~9, for 2001~2009
 Month: 1~9, A~C, for Jan. ~ Dec.
 Day: 1~9, A~Y, for 1st to 31st, exclude I , O and U
- (b) Revision Code: cover all the change
- (c) Serial No.: Manufacturing sequence of product

4-M3
DP=4.5mm max. Screw Penetration

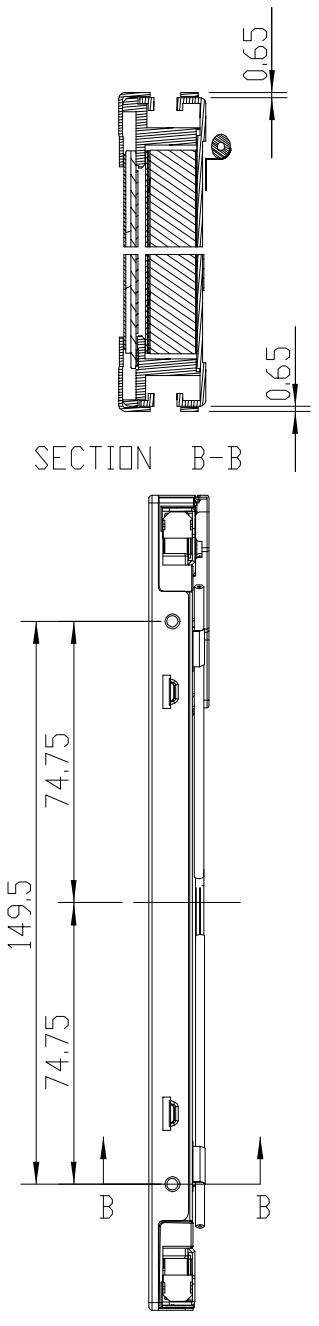
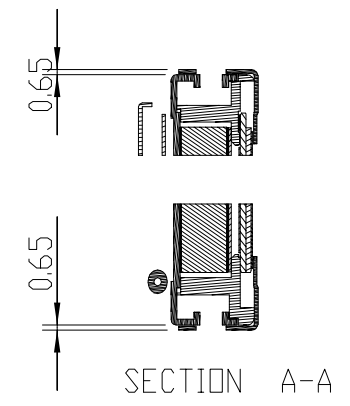
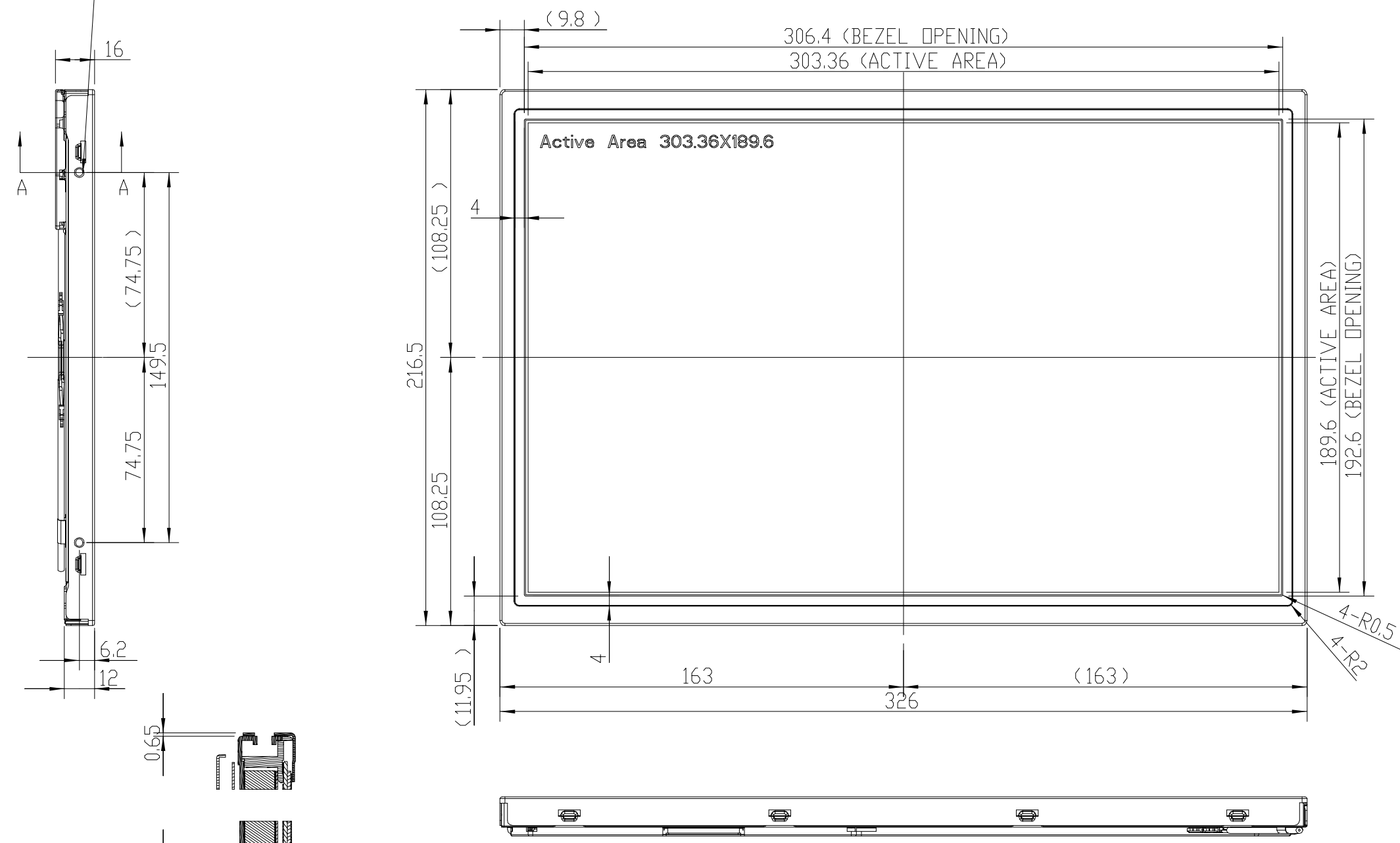

DATA MODUL

TITLE		ASSY_MODULE_G1411-L01		2D REV. 01	
				3D REV. 01	
Approved	YULE_LIN	Drawing No.	G141141011		
Checked	TIGER_CHANG	Part No.	GE11101901		
Drawer	TAURUS_HSIEH	Material	TBD	Sheet	1 / 2 A3
Designer	TAURUS_HSIEH	Date	15-May-2008	Scale	1:1 Unit:mm
		CHI MEI		ALL RIGHTS RESERVED, COPYING FORBIDDEN.	
		OPTOELECTRONICS CORP.			

Mark	Description	Date	Changed_By	Approved_By	ECN No.	Remark
1						
2						
3						
4						
5						
6						
7						
8						

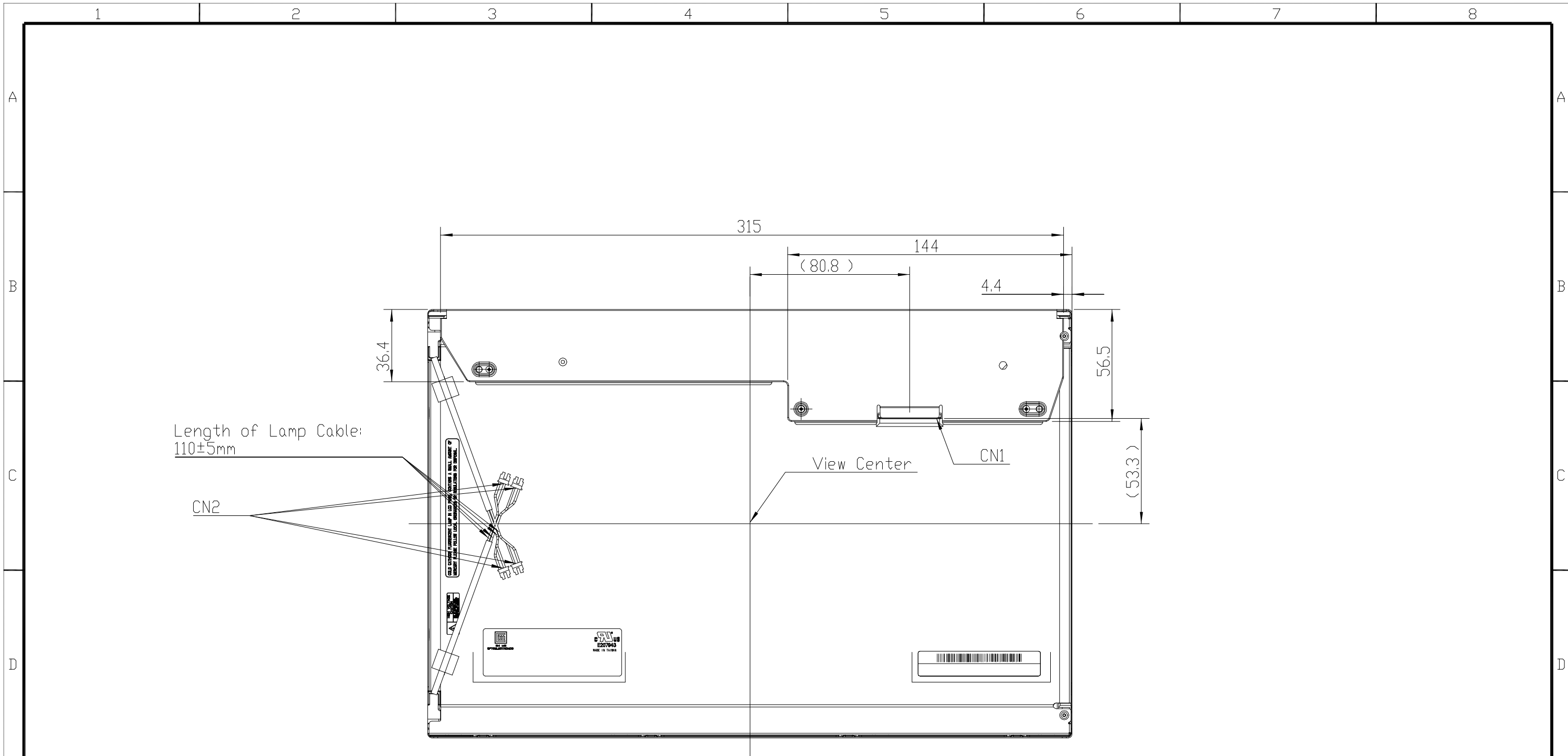

CN1:FI-SE20P-HFE(JAE)
 CN2:35001HS-02L(YEONHD)

DATA MODUL

TITLE		ASSY_MODULE_G141I1-L01		2D REV. 01	
				3D REV. 01	
Approved	YULE_LIN	Drawing No.	G141141011		
Checked	TIGER_CHANG	Part No.	GE11101901		
Drawer	TAURUS_HSIEH	Material	TBD	Sheet	2 / 2 A3
Designer	TAURUS_HSIEH	Date	15-May-2008	Scale	1:1 Unit:mm

 **CHI MEI**
 OPTOELECTRONICS CORP. ALL RIGHTS RESERVED, COPYING FORBIDDEN.

Mark	Description	Date	Changed_By	Approved_By	ECN No.	Remark
1						
2						
3						
4						
5						



Data Modul Headquarters Munich
Landsberger-Str. 322
D-80687 Munich - Germany
Tel.: +49-89-56017-0



Sales Office Duesseldorf
Fritz-Vomfelde-Str. 8
D-40547 Duesseldorf - Germany
Tel.: +49-211-52709-0



Sales Office Stuttgart
Friedrich-List-Str. 42
D-70771 Leinfelden-Echterdingen
Germany
Tel.: +49-711-782385-0



Data Modul France, S.A.R.L.
Bat B - Hall 204
1-3 Rue des Campanules
77185 Lognes - France
Tel.: +33-1-60378100



Data Modul Italia, S.r.l.
Regus Center Senigallia
Via Senigallia 18/2
20161 Milano - Italy
Tel.: +39-02-64672-509



Data Modul Iberia, S.L.
c/ Adolfo Pérez Esquivel 3
Edificio Las Americas III Oficiana 40
28230 Parque Empresarial
Madrid Las Rozas - Spain
Tel.: +34-916 366 458



Data Modul Ltd. / UK
3 Brindley Place
Birmingham B 12JB
United Kingdom
Tel.: +44-121-698-8641

Data Modul Inc. / USA
1767-46 Veterans Memorial Highway
Islandia NY 11749
USA
Tel.: +1-877-951-0800