



Specification

CLAA057VA01CW
5.7" / 640x480 / TTL / LED

Version July 2008

CONTENTS

1. OVERVIEW	4
2. ABSOLUTE MAXIMUM RATINGS	5
3. ELECTRICAL CHARACTERISTICS	6
3.1TFT LCD	6
3.2TFT-LCD current consumption.....	6
3.3 Power 、 Signal sequence	7
4. INTERFACE CONNECTION	8
5. INPUT SIGNAL(DE ONLY MODE)	10
5.1 Timing Specification	10
5.2 Timing sequence(Timing chart).....	11
5.3 Color Data Assignment.....	13
6. BLOCK DIAGRAM	14
7. MECHANICAL DIMENSION	15
7.1 Front Side	15
7.2 Rear Side	16
8. OPTICAL CHARACTERISTICS	17
9. RELIABILITY TEST	19
9-1. Temperature and humidity.....	19
9-2. Shock and Vibration.....	19
9-3. Judgment standard	19

1. OVERVIEW

CLAA057VAO1CW is 5.7" color TFT-LCD(Thin Film Transistor Liquid Crystal Display)module composed of LCD panel,driver ICs,control circuit,and LED backlight.

The 14.52cm(5.7") screen produces a high resolution image that is composed of 640×480 pixel elements in a stripe arrangement.Display 262K colors by 6 Bit R.G.B signal input.Use 3.3 Voltage to drive the power of LCD system,and 5 Voltage to drive the LED back light.

General specifications are summarized in the following table:

ITEM	SPECIFICATION
Panel Size	5.7 inch(panel diagonal)
Display Area (mm)	116.16(W)×87.12(H)
Number of Pixels	640×3(H)×480(V)
Pixel Pitch (mm)	0.1815(H)×0.1815(V)
Color Pixel Arrangement	RGB vertical stripe
Display Mode	Normally white
Number of colors	262,144
Viewing Direction	6 o'clock
Response Time (Tr+Tf)	30ms
Brightness(cd/m ²)	220nit(typ)
Viewing Angle(BL on,CR ≥ 10)	140 degree(H) · 100degree(V)
Electrical Interface(data)	TTL
Power consumption(W)	2W
Outline Dimension(in mm)	127(W)×100(H)×6.6(D)
Weight(g)	110g
BL unit	LED
Surface Treatment	Anti-Glare · Hardness:3H

2. ABSOLUTE MAXIMUM RATINGS

Item	Symbol	Min.	Max.	Unit	Note
Power Supply Voltage	Vcc	-0.5	5.0	V	
Signal Input Voltage	DCLK,DE,R0,G0 ,B0~R5,G5,B5	-0.5	Vcc + 0.5	V	
Static Electricity	VESDc	-200	+200	V	*2)
	VESDm	-15K	+15K	V	
ICC Rush Current	IRUSH	-	1	A	*3)
Operation Temperature	T _{op}	-30	85		*1)
Storage Temperature	T _{stg}	-40	95		*1)

Remarks :

- *1) If users use the product out off the environment operation range (temperature and humidity) ,it will concern for visual quality.
- *2) Test Condition: IEC 61000-4-2 ,
VESDc : Contact discharge to input connector
VESDm : Contact discharge to module
- *3) The input pulse-current measurement system as below :

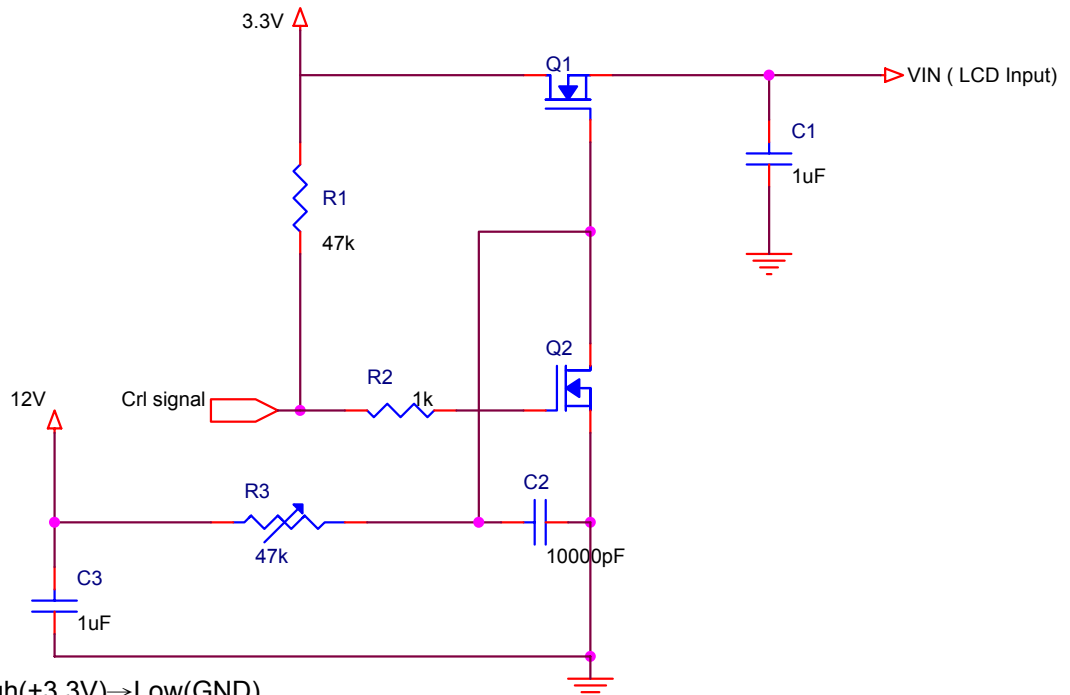

Control signal:High(+3.3V)→Low(GND)

Supply Voltage of rising time should be from R3 and C2 tune to 550 us.

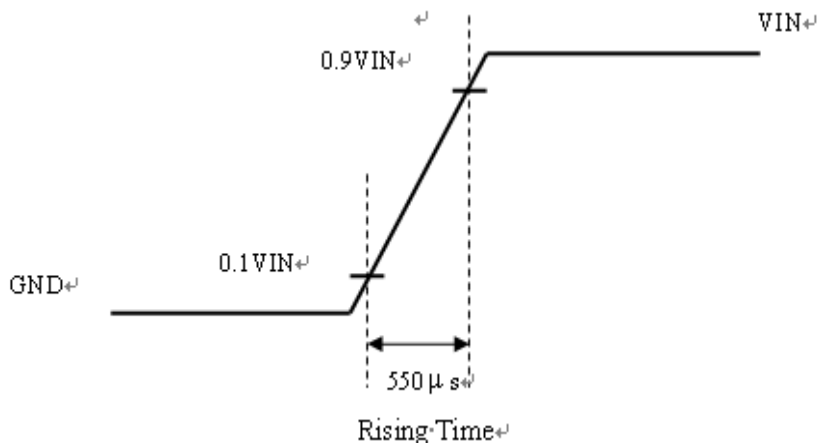

3. ELECTRICAL CHARACTERISTICS

3.1TFT LCD

Ta=25

Item	Symbol	Min.	Typ	Max.	Unit	Note
Power Supply Voltage For LCD	V_{CC}	3.0	3.3	3.6	V	*1)
Power Supply Voltage For LED	V_{LED}	4.5	5	5.5	V	
Logic Input Voltage	V_{IH}	$V_{CC} \cdot 0.7$	--	V_{CC}	V	
	V_{IL}	0	--	$V_{CC} \cdot 0.3$	V	
ADJ Input Voltage	V_{IH}	3.0	--	3.3	V	
	V_{IL}	GND	--	0.3	V	

Remarks :

*1) VCC –dip condition:

When $2.7\text{ V} < V_{CC} < 3.0\text{ V}$, $t_d = 10\text{ ms}$.

$V_{CC} > 3.0\text{ V}$, VCC-dip condition should be same as VCC-turn-on condition.

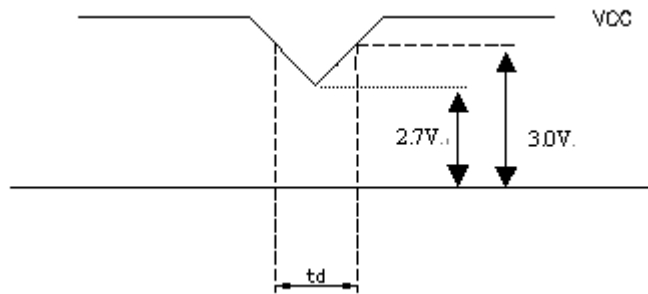

3.2TFT-LCD current consumption

Item	Symbol	Min.	Typ	Max.	Unit	Note
LCD power current	I_{CC}	--	140	190	mA	*1)
LED power current	I_{LED}		300	350	mA	*2)

*1) Typical: Under 64 gray pattern

Maximum: Under black pattern

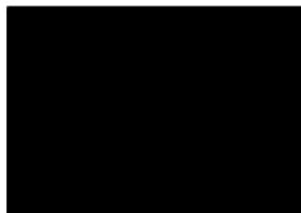

(a) 64 Gray Pattern (b) Black Pattern

*2) Typical: When V_{LED} is 5.0V

Maximum: When V_{LED} is 4.5V

3.3 Power & Signal sequence

t1	10ms	1 sec	t5
50ms	t2	200ms	t6
0 < t3	50ms	200ms	t7
0 < t4	10ms		

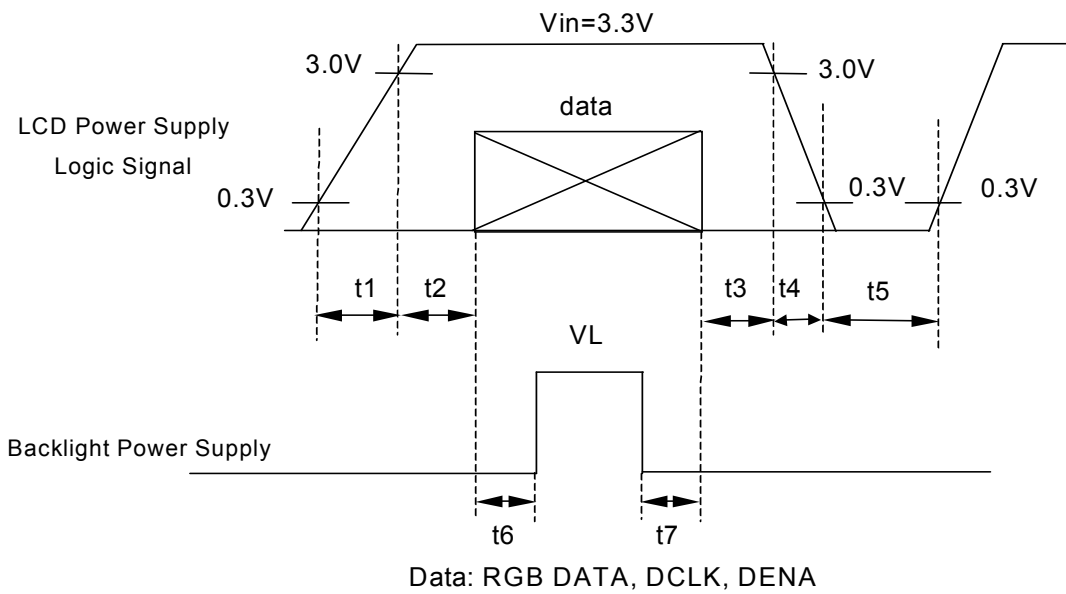

4. INTERFACE CONNECTION

(a) CN1 : Starconn 089N40-000R00-G2

Pin NO.	SYMBOL	DESCRIPTION
1	U/D	Up / Down Display Control
2	DMS	DE / SYNC Mode Selection
3	Hsync	Horizontal SYNC.
4	V _{LED}	Power Supply for LED
5	V _{LED}	Power Supply for LED
6	V _{LED}	Power Supply for LED
7	V _{CC}	Power Supply for LCD
8	V _{sync}	Vertical SYNC.
9	DE	Data Enable
10	V _{SS}	Power Ground
11	V _{SS}	Power Ground
12	ADJ	Adjust for LED brightness
13	B5	Blue Data 5 (MSB)
14	B4	Blue Data 4
15	B3	Blue Data 3
16	V _{SS}	Power Ground
17	B2	Blue Data 2
18	B1	Blue Data 1
19	B0	Blue Data 0 (LSB)
20	V _{SS}	Power Ground
21	G5	Green Data 5 (MSB)
22	G4	Green Data 4
23	G3	Green Data 3
24	V _{SS}	Power Ground
25	G2	Green Data 2
26	G1	Green Data 1
27	G0	Green Data 0 (LSB)
28	V _{SS}	Power Ground
29	R5	Red Data 5 (MSB)
30	R4	Red Data 4
31	R3	Red Data 3
32	V _{SS}	Power Ground
33	R2	Red Data 2
34	R1	Red Data 1
35	R0	Red Data 0 (LSB)
36	V _{SS}	Power Ground
37	V _{SS}	Power Ground
38	DCLK	Clock Signals
39	V _{SS}	Power Ground
40	L/R	Left / Right Display Control

Remarks :

1).ADJ adjust brightness to control Pin · Pulse duty the bigger the brighter.



2) ADJ signal = 0~3.3V · operation frequency: 20±10KHZ

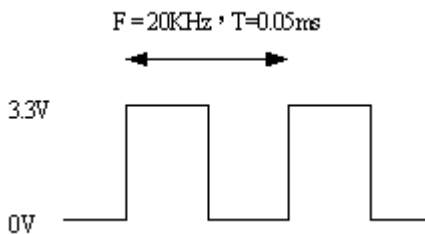

3) VSS Pin must ground contact · can not be floating.

4) U/D and L/R are controled function

L/R	U/D	Function
1	0	Normally display
0	0	Left and Right opposite
1	1	Up and Down opposite
0	1	Left and Right opposite · Up and Down opposite

*5) DMS (Selection DE / SYNC mode)

DMS	Function
1	DE Mode
0	SYNC Mode

5. INPUT SIGNAL(DE ONLY MODE)

5.1 Timing Specification

characteristics		SYMBOL	MIN.	TYP.	MAX.	UNIT	REMARK
DE MODE	Dot Clock	F_{OSC}	23	25	30	MHz	
	Horizontal Period	T_H	750	800	900	T_{OSC}	
	Horizontal Valid	T_{HV}	640				
	Horizontal Blank	T_{HKB}	110	160	260		
	Vertical Period	T_{VP}	515	525	560	T_H	
	Vertical Valid	T_{VV}	480				
	Vertical Blank	T_{VKB}	35	45	80		
	Vertical Frequency	F_V	55	60	65	Hz	
SYNC MODE	Horizontal Period	T_H	750	800	900	T_{OSC}	
	Horizontal Pulse Width	T_{HS}	1	1	1		
	Horizontal Pulse Width + Back Proch	T_{HPWB}	46	46	46		
	Horizontal Front Proch	T_{HF}	64	114	214		
	Horizontal Valid	T_{HV}	640				
	Vertical Period	T_{VP}	515	525	560	T_H	
	Vertical Pulse Width	T_{VS}	1	1	1		
	Vertical Pulse Width + Back Proch	T_{VPWB}	34	34	34		
	Vertical Front Proch	T_{VF}	1	11	46		
	Vertical Valid	T_{VV}	480				
	Vertical Frequency	F_V	55	60	65		Hz

5.2 Timing sequence(Timing chart)

Horizontal Timing Sequence

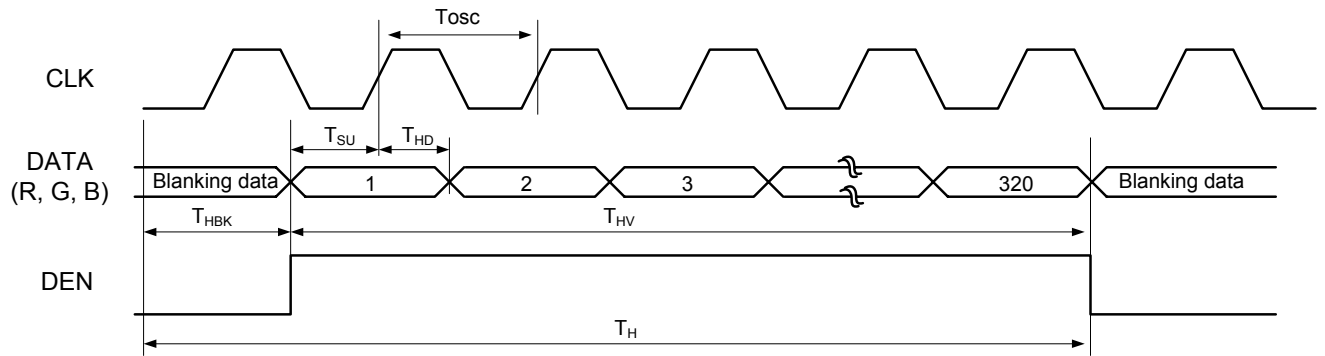

Vertical Timing Sequence

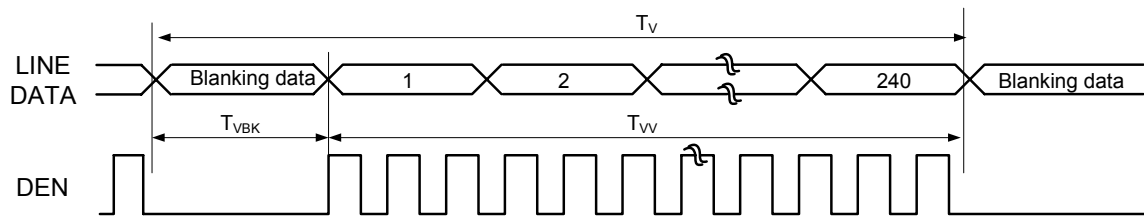

DE mode Timing

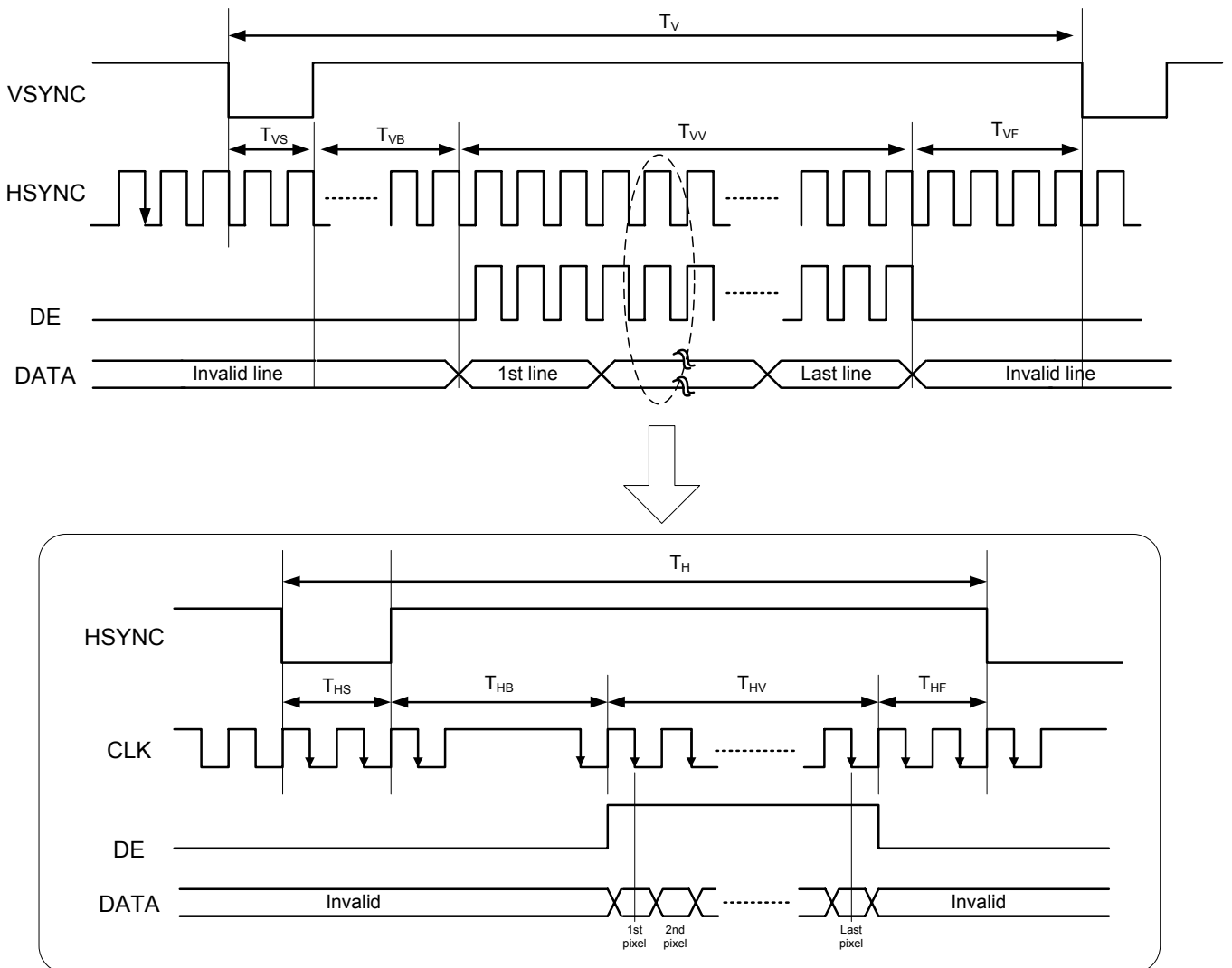

Sync mode Timing

5.3 Color Data Assignment

COLOR	INPUT	R DATA						G DATA						B DATA					
		R5	R4	R3	R2	R1	R0	G5	G4	G3	G2	G1	G0	B5	B4	B3	B2	B1	B0
	DATA	MSB					LSB	MSB					LSB	MSB					LSB
	BLACK	0	0	0	0	0	0	0	0	0	0	0	0	0	0	0	0	0	0
	RED(63)	1	1	1	1	1	1	0	0	0	0	0	0	0	0	0	0	0	0
BASIC	GREEN(63)	0	0	0	0	0	0	1	1	1	1	1	1	0	0	0	0	0	0
COLOR	BLUE(63)	0	0	0	0	0	0	0	0	0	0	0	0	1	1	1	1	1	1
	CYAN	0	0	0	0	0	0	1	1	1	1	1	1	1	1	1	1	1	1
	MAGENTA	1	1	1	1	1	1	0	0	0	0	0	0	1	1	1	1	1	1
	YELLOW	1	1	1	1	1	1	1	1	1	1	1	1	0	0	0	0	0	0
	WHITE	1	1	1	1	1	1	1	1	1	1	1	1	1	1	1	1	1	1
	RED(0)	0	0	0	0	0	0	0	0	0	0	0	0	0	0	0	0	0	0
	RED(1)	0	0	0	0	0	1	0	0	0	0	0	0	0	0	0	0	0	0
	RED(2)	0	0	0	0	1	0	0	0	0	0	0	0	0	0	0	0	0	0
RED																			
	RED(62)	1	1	1	1	1	0	0	0	0	0	0	0	0	0	0	0	0	0
	RED(63)	1	1	1	1	1	1	0	0	0	0	0	0	0	0	0	0	0	0
	GREEN(0)	0	0	0	0	0	0	0	0	0	0	0	0	0	0	0	0	0	0
	GREEN(1)	0	0	0	0	0	0	0	0	0	0	0	1	0	0	0	0	0	0
	GREEN(2)	0	0	0	0	0	0	0	0	0	0	1	0	0	0	0	0	0	0
GREEN																			
	GREEN(62)	0	0	0	0	0	0	1	1	1	1	1	0	0	0	0	0	0	0
	GREEN(63)	0	0	0	0	0	0	1	1	1	1	1	1	0	0	0	0	0	0
	BLUE(0)	0	0	0	0	0	0	0	0	0	0	0	0	0	0	0	0	0	0
	BLUE(1)	0	0	0	0	0	0	0	0	0	0	0	0	0	0	0	0	0	1
	BLUE(2)	0	0	0	0	0	0	0	0	0	0	0	0	0	0	0	0	1	0
BLUE																			
	BLUE(62)	0	0	0	0	0	0	0	0	0	0	0	0	1	1	1	1	1	0
	BLUE(63)	0	0	0	0	0	0	0	0	0	0	0	0	1	1	1	1	1	1

Remarks :

(1) Definition of Gray Scale

color(n) : n is series of Gray Scale

The more n value is, the bright Gray Scale.

(2)Data:1-High,0-Low

6. BLOCK DIAGRAM

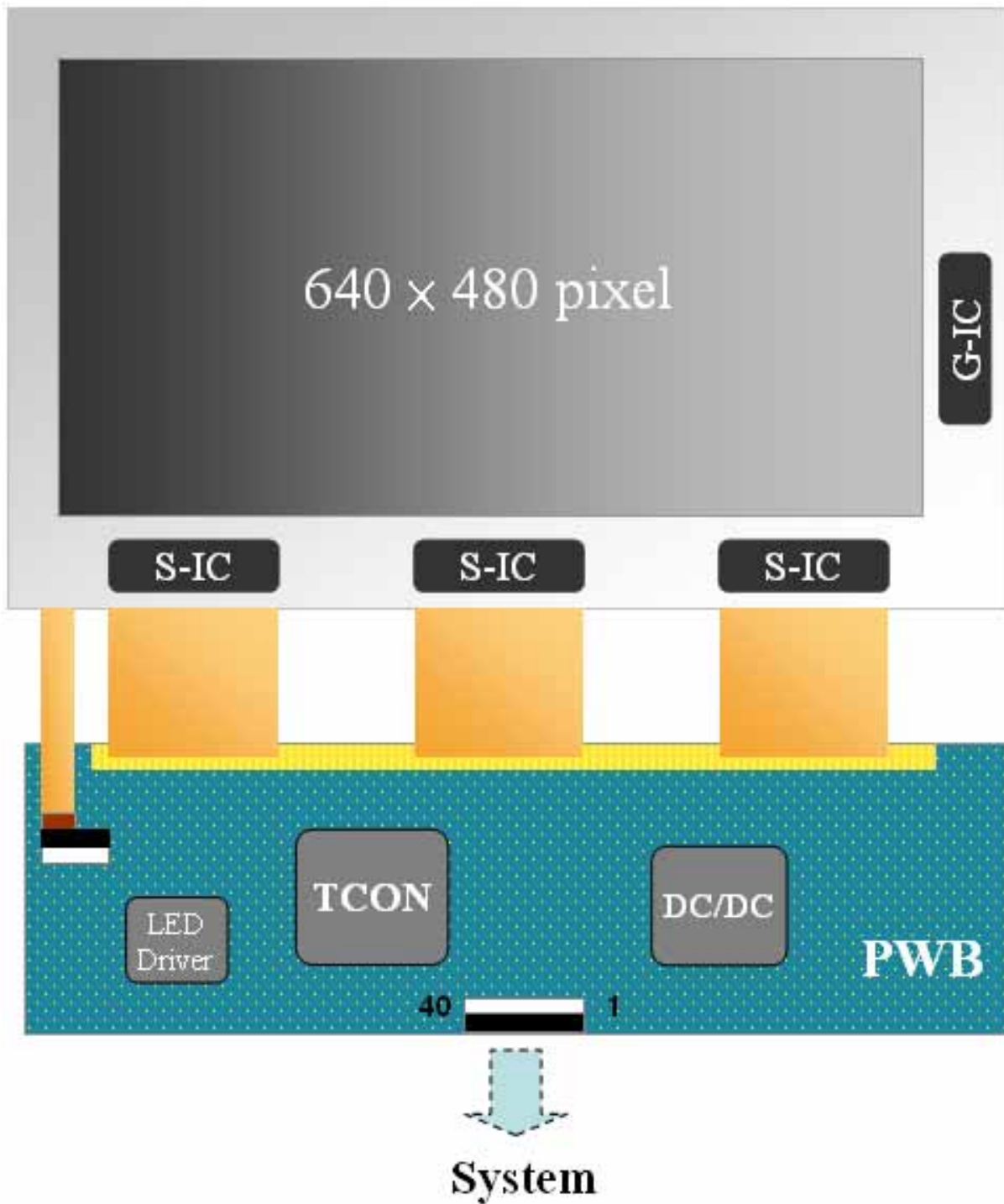

7. MECHANICAL DIMENSION

7.1 Front Side

[Unit : mm]

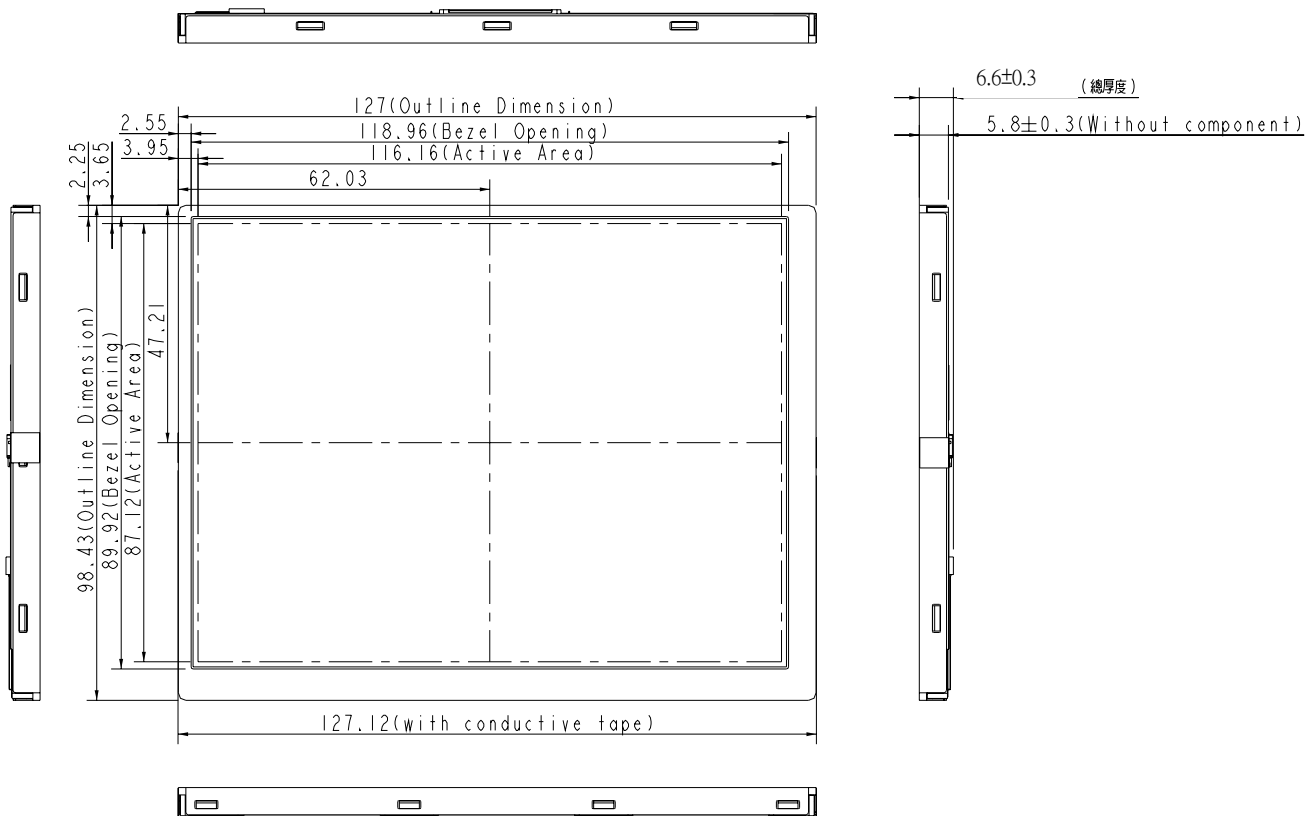

NOTE:
General tolerance: ± 0.3

7.2 Rear Side

[Unit : mm]

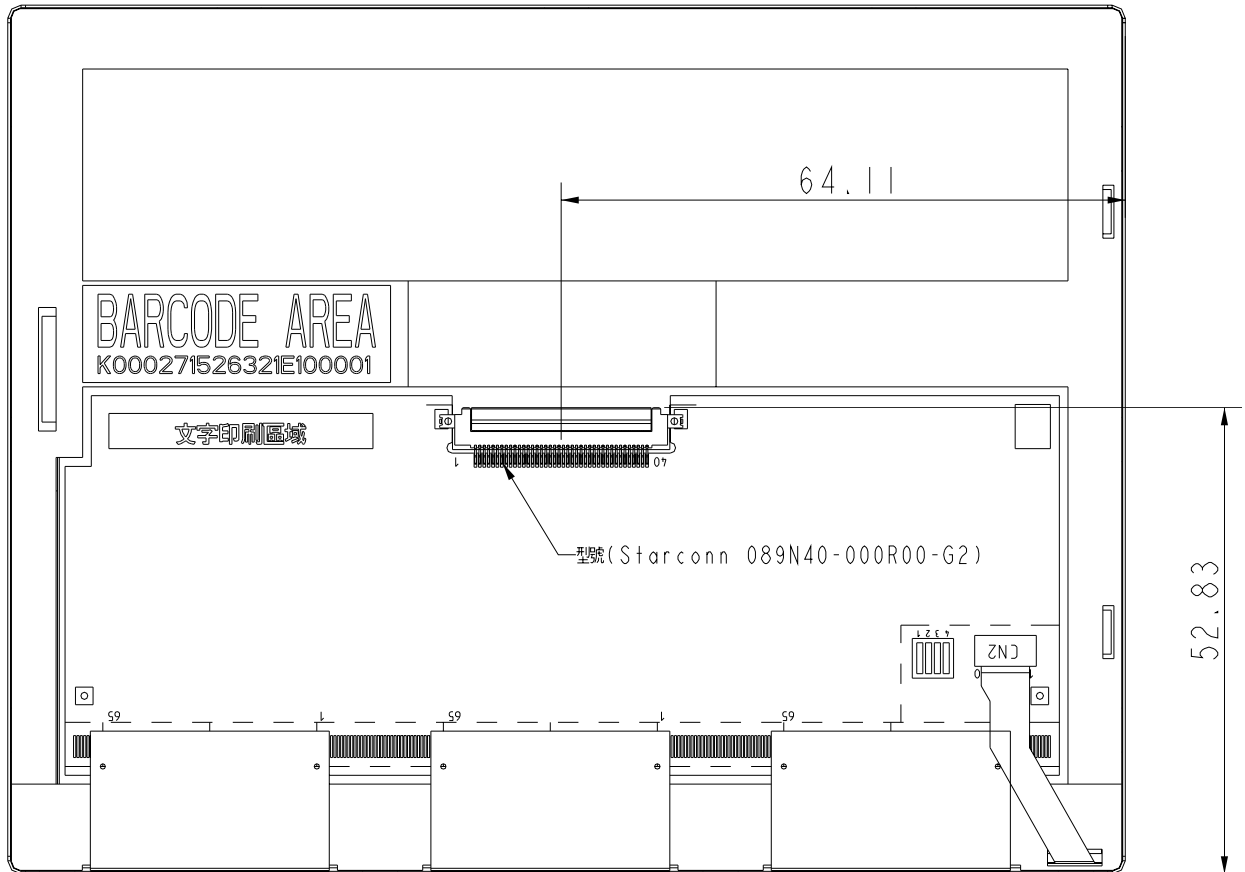

Remark : Un-indication tolerance is $\pm 0.3\text{mm}$

8. OPTICAL CHARACTERISTICS

ITEM	SYMBOL	CONDITION	MIN.	TYP.	MAX.	UNIT	Remarks	
Constrast Ratio	CR	Point-5	200	300	--	--	*1)*2)*3)	
Luminance	Lw	Point-5	180	220	--	cd/m ²	*1)*3)	
Luminance Uniformity	ΔL		70	80	--	%	*1)*3)	
Response Time (White - Black)	Tr+ Tf	Point-5	--	30	50	ms	*1)*3)*5)	
Viewing Angle	Horizontal	ϕ	CR 10 Point-5	120	140	--	°	*1)*2)*4)
	Vertical	θ		80	100	--	°	*1)*2)*4)
Color Coordinate	White	Wx Wy	Point-5	0.283 0.299	0.313 0.329	0.343 0.359	--	*1)*3)
	Red	Rx Ry		0.580 0.306	0.610 0.336	0.640 0.366		
	Green	Gx Gy		0.300 0.544	0.330 0.574	0.360 0.604		
	Blue	Bx By		0.116 0.080	0.146 0.110	0.176 0.140		

Remarks :

*1)Measure condition : 25 ±2 °, 60±10%RH , under10 Lux in the dark room.BM-5A (TOPCON) , viewing angle2° , VCC=3.3V , VDD=3.3V.

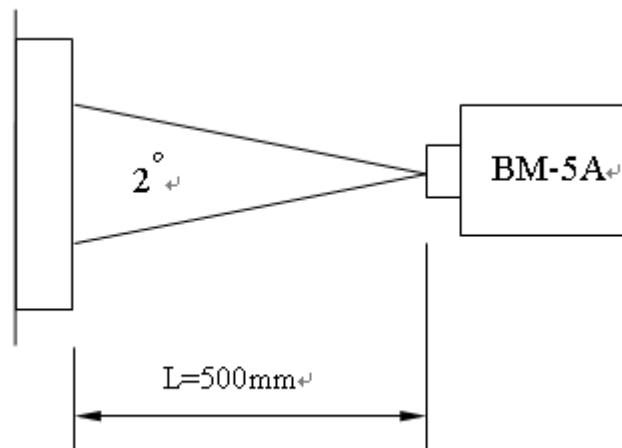

*2) Definition of contrast ratio :

Contrast Ratio (CR)= (White) Luminance of ON ÷ (Black) Luminance of OFF

*3) Definition of luminance :

Definition of Luminance Uniformity:

Measure white luminance on the point 5 as figure8-1

Measure white luminance on the point1~9 as figure8-1

$$L = [L(\text{MIN})/L(\text{MAX})] \times 100\%$$

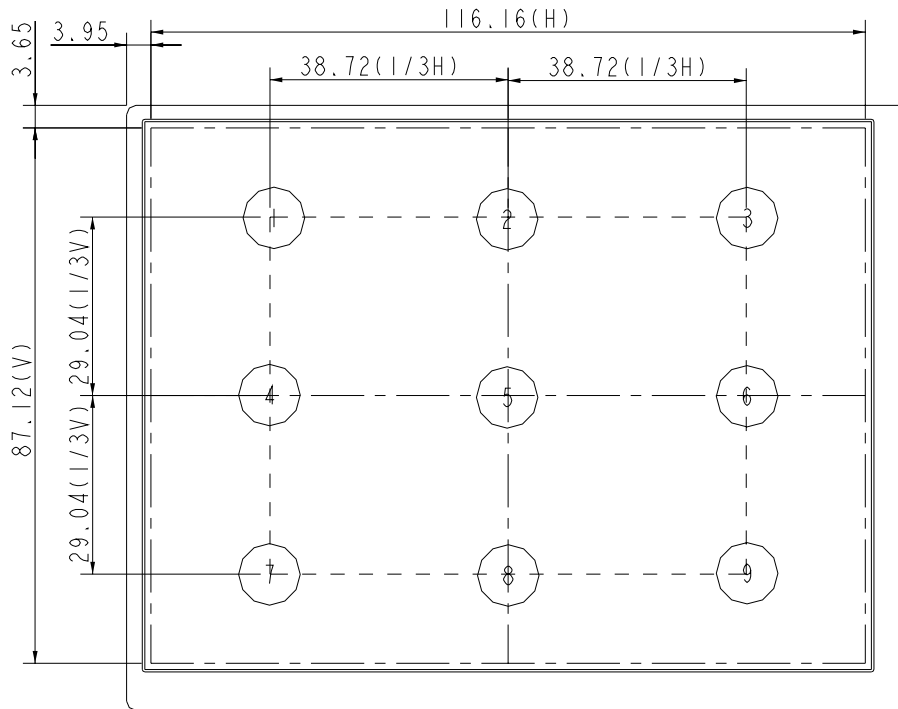

Fig8-1 Measuring point

*4) Definition of Viewing Angle(θ, ψ), refer to Fig8-2 as below :

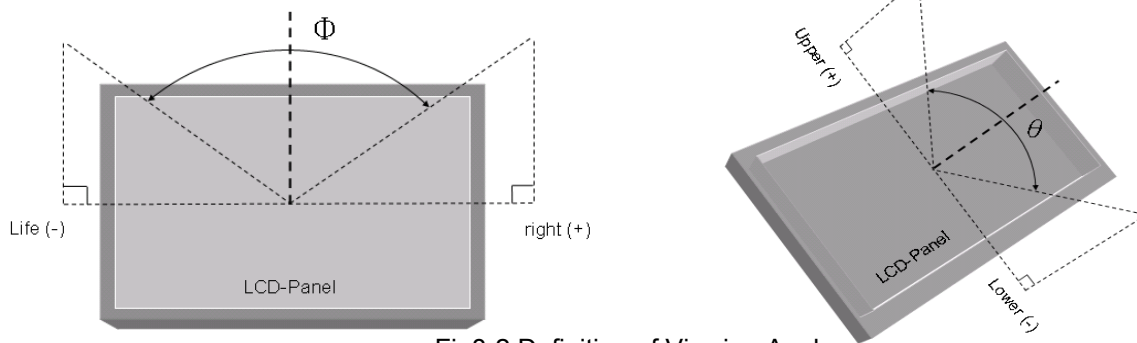

Fig8-2 Definition of Viewing Angle

*5) Definition of Response Time.(White-Black)

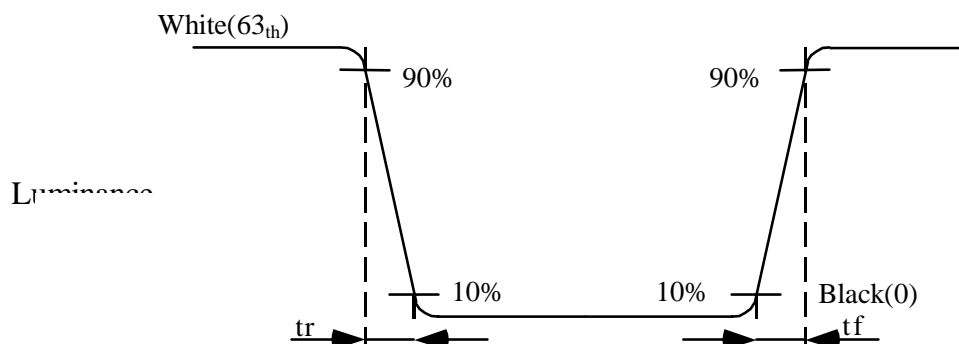

Fig8-3 Definition of Response Time(White-Black)

9. RELIABILITY TEST

9-1. Temperature and humidity

TEST ITEMS	CONDITIONS
High Temperature Operation	85°C , 240H
High Temperature Storage	95°C , 240H
High Temperature High Humidity Operation	60°C , 90%RH , 240H(No condensation)
Low Temperature Operation	-30°C , 240H, Backlight unit always turn on
Low Temperature Storage	-40°C , 240H
Thermal Shock	-30°C (0.5Hr) ~ 85°C(0.5Hr) 200 cycles

9-2. Shock and Vibration

TEST ITEMS	CONDITIONS
Shock (Non-operation)	<ul style="list-style-type: none"> ● Shock level:980m/s²(equal to 100G) ● Waveform:half sinusoidal wave,6ms. ● Number of shocks:one shock input in each direction of three mutually perpendicular axes for a total of three shock inputs.
Vibration (Non-operation)	<ul style="list-style-type: none"> ● Frequency range:8~33.3Hz ● Stroke:1.3mm ● Vibration:sinusoidal wave,perpendicularaxis(both x,y,z axis:2Hrs). ● Sweep:2.9G,33.3Hz-400Hz ● Cycle:15min
LED life time	20000 Hr

9-3. Judgment standard

The Judgment of the above test should be made as follow:

Pass:Normal display image with no obvious non-uniformity and no line defect.Partial transformation of the module parts should be ignored.

Fail:No display image,obvious non-uniformity,or line defect.



Data Modul Headquarters Munich
Landsberger-Str. 322
D-80687 Munich - Germany
Tel.: +49-89-56017-0



Sales Office Duesseldorf
Fritz-Vomfelde-Str. 8
D-40547 Duesseldorf - Germany
Tel.: +49-211-52709-0



Sales Office Hamburg
Borsteler Chaussee 51
D-22453 Hamburg - Germany
Tel.: +49-40-42947377 - 0

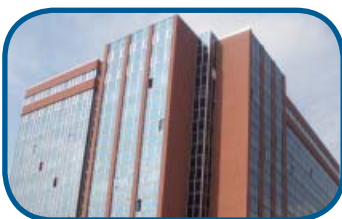

Sales Office Stuttgart
Friedrich-List-Str. 42
D-70771 Leinfelden-Echterdingen
Germany
Tel.: +49-711-782385-0



Data Modul France, S.A.R.L.
Bat B - Hall 204
1-3 Rue des Campanules
77185 Lognes - France
Tel.: +33-1-60378100



Data Modul Italia, S.r.l.
Regus Center Senigallia
Via Senigallia 18/2
20161 Milano - Italy
Tel.: +39-02-64672-509



Data Modul Iberia, S.L.
c/ Adolfo Pérez Esquivel 3
Edificio Las Americas III Oficiana 40
28230 Parque Empresarial
Madrid Las Rozas - Spain
Tel.: +34-916 366 458

Data Modul Ltd. / UK
3 Brindley Place
Birmingham B 12JB
United Kingdom
Tel.: +44-121-698-8641

Data Modul Inc. / USA
1767-46 Veterans Memorial Highway
Islandia NY 11749
USA
Tel.: +1-877-951-0800